

USER'S HANDBOOK

for

THE DATRON 4200 AUTO CAL AC STANDARD

850051

Issue C (JAN 1985)

For any assistance contact your nearest Datron Sales and Service center.
Addresses can be found at the back of this handbook.

Due to our policy of continuously updating our products, this handbook may contain minor differences in specification, components and circuit design to the instrument actually supplied. Amendment sheets precisely matched to your instrument serial number are available on request.

© 1985 Datron Instruments



DANGER HIGH VOLTAGE



**THIS INSTRUMENT IS CAPABLE
OF DELIVERING
A LETHAL ELECTRIC SHOCK!**



FRONT or REAR
terminals carry the
Full Output Voltage.

THIS CAN KILL!

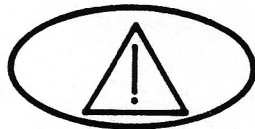

Guard terminal is
sensitive to over-
voltage

**It can damage
your instrument!**

Unless **you** are **sure** that
it is **safe** to do so,
DO NOT TOUCH the
I+ I- Hi or Lo leads
and **terminals**

DANGER

CONTENTS

	Page
SECTION 1 THE DATRON 4000 AUTOCAL STANDARD	
Introduction	1-1
Standard Facilities	1-1
SAFETY	1-2
Optional Facilities	1-3
Accessories	1-3
Additional Documentation	1-3
Principles of Operation	1-4
Option 30 Current Output	1-5
SECTION 2 INSTALLATION	
Unpacking and Inspection	2-1
Preparation for Operation	2-1
Bench Mounting	2-2
Rack Mounting	2-2
Connectors and Pin Designations	2-3
SECTION 3 OPERATING CONTROLS	
Front Panel	3-1
Front Panel Keys	3-1
Power Switch	3-1
OUTPUT Switching	3-2
FUNCTION Keys	3-3
OUTPUT RANGE Keys	3-3
OUTPUT Display and \uparrow/\downarrow Keys	3-4
Frequency	3-5
MODE Selection Keys	3-8
I+, I-, Hi, Lo, Guard and Ground Terminals	3-9
Rear Panel	3-10
SECTION 4 USING THE DATRON 4200	
Preliminaries	4-1
Limiting Characteristics	4-1
SAFETY	4-1
Interconnections	4-2
Importance of Correct Connections	4-2
Remote/Local Sense	4-3
4200 - Connections to the Load	4-3
General Sequence of Operations	4-6
Operating Routines	4-7
AC Voltage Outputs	4-7
AC Current Outputs	4-8
Additional Facilities	4-9
Change of Output Display Resolution	4-9
Frequency Store	4-10
Spot Frequency	4-11
Specification Mode	4-12
Error Mode	4-14
Test Key	4-17
Test Sequence	4-17
Messages and Warnings	4-20

	Page
SECTION 5 SYSTEMS APPLICATION VIA THE IEEE 488 INTERFACE	5-1
Introduction	5-1
Interface Capability	5-1
Bus Addresses	5-2
Typical System	5-3
Using the 4200 in a System	5-4
Programming Instructions	5-5
Programming of Operational Functions	5-8
Programming of Bus Transmissions	5-10
Activation of Commands	5-14
Multiple Commands	5-14
Operational Sequence Guidelines	5-15
 SECTION 6 SPECIFICATIONS	 6-1
General	6-1
AC Voltage	6-2
AC Current	6-4
 SECTION 7 SPECIFICATION VERIFICATION	 7-1
Introduction	7-1
Equipment Requirements	7-2
Notes on the use of the Thermal Transfer Standard	7-3
Preparation	7-3
Voltage Verification Procedure	7-4
Current Verification Procedure	7-5
Voltage Verification Report Sheet - 90 day limits	7-6
Voltage Verification Report Sheet - Limit Calculations	7-7
Current Verification Report Sheet - 90 day limits	7-8
Current Verification Report Sheet - Limit Calculations	7-9
 SECTION 8 ROUTINE AUTOCALIBRATION	 8-1
The 4200 Autocal Feature	8-1
"Wideband Calibration"	8-2
Spot Calibration	8-2
SET Calibration	8-2
STANDARD Calibration	8-2
Calibration Procedures	8-3
General Procedure	8-3
Voltage Calibration Procedure	8-4
Current Calibration Procedure	8-5

DATRON SALES AND SERVICE REPRESENTATIVES WORLDWIDE

Inside Rear Cover

Note to Readers

This handbook has been designed for you to get the best use from your 4200. Here is a more explanatory version of the Section Titles:

- Sect 1. Introduction and a brief account of the internal design.*
- Sect 2. Physical connections and mounting - getting it installed.*
- Sect 3. A brief scan of the available controls - where they are and what they do.*
- Sect 4. The correct procedures for making the 4200 perform.*
- Sect 5. How your 4200 can operate within an IEEE 488 system - the device dependent codes you will need to use.*
- Sect 6. Specifications - what accuracy you can expect to get out of your instrument.*
- Sect 7. Verifications that your 4200 matches the high specification it had when it left the factory.*
- Sect 8. How to restore your 4200 to its original spec. after it has suffered the ravages of time and temperature.*

We are confident that your 4200 will give you many years of accurate and reliable service, and hope that you will use this handbook to obtain maximum benefit from its many facilities.

100
95
90
85
80
75
70
65
60
55
50
45
40
35
30
25
20
15
10
5
0

SECTION 1: THE PROLOGUE

The first chapter of the book is a prologue. It sets the scene for the rest of the work. The author begins by describing the state of the world at the time of the events. He then goes on to describe the events themselves, which are the beginning of a great adventure. The prologue is written in a simple, direct style, and it is very easy to read. It is a good example of how to write a prologue for a book.

SECTION 2: THE BEGINNING

The second chapter of the book is the beginning. It is the start of the main story. The author describes the first few days of the journey. The characters are introduced, and the reader is given a sense of the world they are living in. The beginning is written in a simple, direct style, and it is very easy to read. It is a good example of how to write the beginning of a book.

SECTION 3: THE JOURNEY

The third chapter of the book is the journey. It is the middle of the main story. The author describes the journey of the characters as they travel through the world. The journey is written in a simple, direct style, and it is very easy to read. It is a good example of how to write the middle of a book.

SECTION 4: THE END

The fourth chapter of the book is the end. It is the conclusion of the main story. The author describes the final events of the journey. The end is written in a simple, direct style, and it is very easy to read. It is a good example of how to write the end of a book.

SECTION 5: THE EPILOGUE

The fifth chapter of the book is the epilogue. It is the final chapter of the work. The author describes the state of the world at the end of the events. The epilogue is written in a simple, direct style, and it is very easy to read. It is a good example of how to write an epilogue for a book.

SECTION 1 THE DATRON 4000 AND 4000 A AUTOCAL STANDARDS

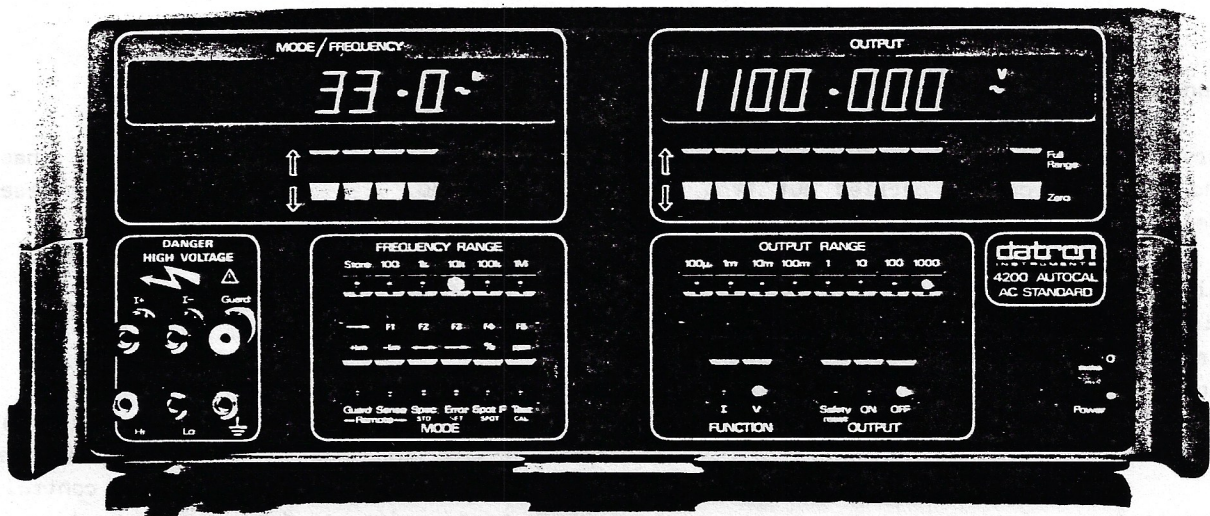

General View of Datron 4200 Autocal AC Standard

Introduction

The Datron 4200 Autocal AC Standard is a high-precision AC calibrator which features exceptionally high stability and full systems capability. It is characterized by a wide-range coverage of AC Voltage and AC Current functions in a single unit.

The 4200 incorporates a reference module containing precision temperature-compensation elements, maintaining a high accuracy specification over the ambient temperature range of $23^{\circ}\text{C} \pm 5^{\circ}\text{C}$. A high level of stability is achieved by use of super-selected reference components and ultra-stable gain-defining resistors. The 'Autocal' feature ensures that its 24-hour specifications are usable; not merely figures of merit.

The 4200 uses a microprocessor for control management, simplifying its use in complex manual operations, such as calibration of high-quality digital multimeters. The IEEE 488 interface provides a comprehensive remote programming capability, allowing programmed calibration of the 4200 itself.

Standard Facilities

AC Voltage Ranges.

The basic instrument provides AC Voltage calibration facilities in seven decade ranges from 1mV to 1000V. 100% overrange is available on all but the 1000V Range (see section 3 page 3-6).

Resolution and Accuracy.

The resolution is $6\frac{1}{2}$ digits (100nV, 100pA) a unique facility for displaying the specified accuracy of any output voltage.

The 4200 specifications are in Section 6.

Frequency

The output frequency of the 4200 extends from 10Hz to 1MHz in five overlapping decade ranges, at a resolution of 1% of nominal Frequency Range. Any five frequency values within the range of the instrument can be stored in volatile memory. For higher accuracy, five 'Spot Calibrated' frequency values per Output Range can be recalled from non-volatile memory storage.

Autocal

All Datron AUTOCAL instruments are designed to make the removal of the covers for calibration unnecessary, as full routine calibration of all ranges and functions can be carried out from the front panel or over the IEEE-488 bus.

Accidental or unauthorised use of the calibration routine is prevented by a key-operated switch on the instrument rear panel. The procedure for calibrating this instrument is contained in Section 8.

Output Deviation

A user may deviate the output voltage from the output display value by introducing a gain 'Error' within the range $\pm 9.9999\%$.

Remote Sense

The specified output voltage may be sensed at the load, using 4-wire connections. Remote or Local Sense is selectable from the front panel.

Remote Guard

This facility allows the instrument's internal guard shields to be externally connected.

Self-test

On power-up, the internal calibration memory is automatically checked. At any time when the output is off, a user may conduct a sequenced test of the displays, keyboard, safety circuitry and Safety Reset function.

Message Readout

Messages to the user are presented on the MODE display;

The two main groups are:

Fail

An internal fault condition has been detected. This may be resettable.

Error

A user has selected a task which is outside the instrument's capability.

Systems Use

The instrument can form part of a system by means of the IEEE 488 standard digital interface. The method of connecting to the system controller and the command codes are described in Section 5

SAFETY

For protection of the user, safety trip circuits are incorporated to switch the OUTPUT OFF, in the event of instrument failures which might generate dangerous output voltages.

UNDER NO CIRCUMSTANCES SHOULD USERS TOUCH ANY OF THE OUTPUT, SENSE OR GUARD TERMINALS UNLESS THEY ARE FIRST SATISFIED THAT NO DANGEROUS VOLTAGE IS PRESENT.

Optional Facilities

The capability of the 4200 may be extended by the addition of one or more of the following options;

Option 30:

AC current Calibrator (maximum output 2 Amps).

Option 41:

Rear Output (as a factory-wired alternative to front panel output).

Accessories

The instrument is supplied with the following accessories:

Description	Part Number
Power Cable	920012
Set of Calibration keys	700068
User's Handbook	850051
Calibration and Servicing Handbook	850056

In addition the following accessories are available for use with the 4200 instrument:

Description	Part Number
RMK Rack mounting kit (Option 90)	440094
Special Lead kit	440070

Additional Documentation

The Calibration and Servicing Handbook contains information required to adjust and service the 4200 instrument. It contains detailed descriptions of the circuits, trouble-shooting and calibration procedures, parts lists, layout drawings and circuit diagrams.

Principles of Operation

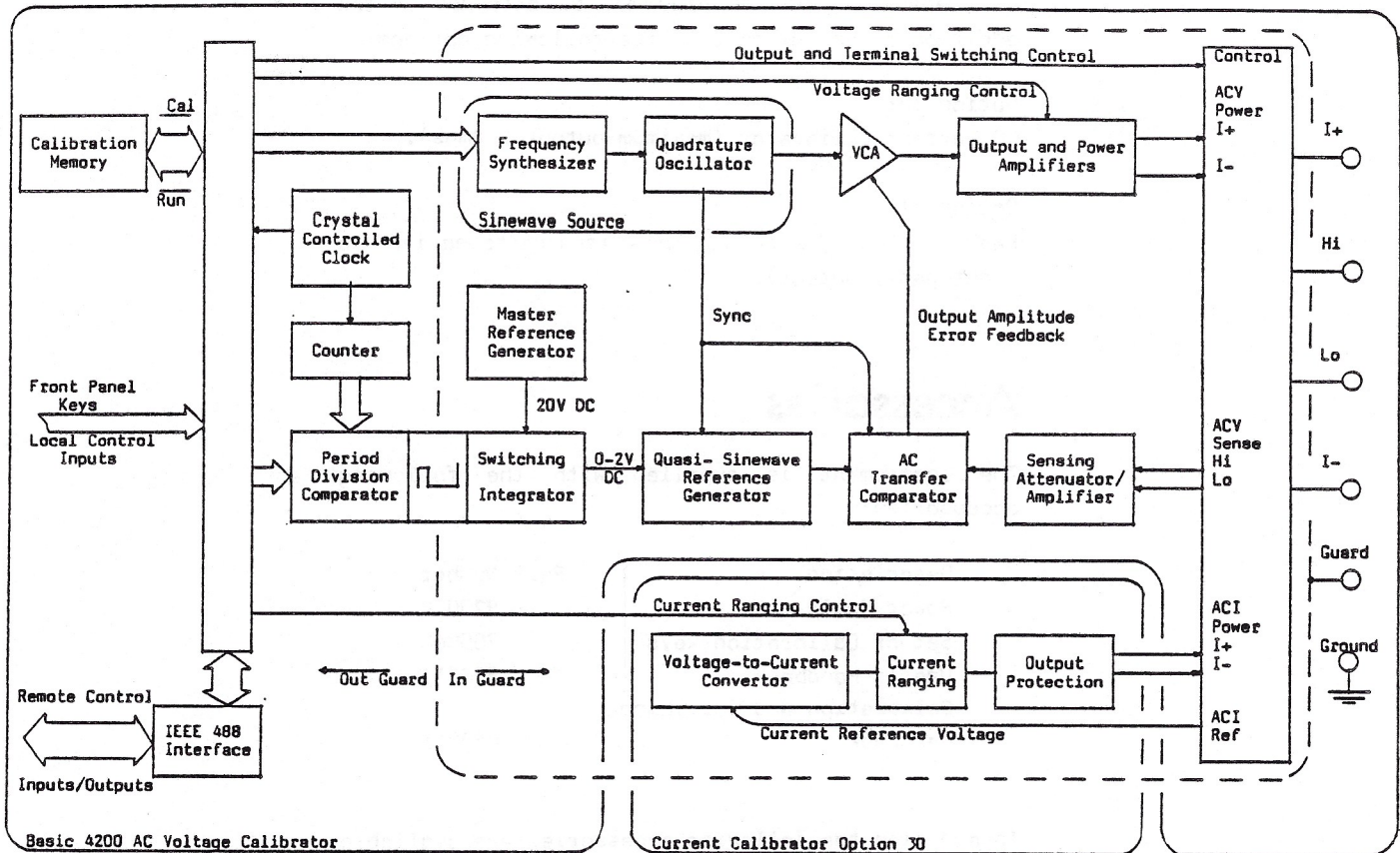

Simplified Functional Diagram. This shows the division and flow of functions within the 4200.

Inputs.

The 6802 microprocessor controls the output in response to three main inputs:

- i) Front panel keys.
- ii) IEEE 488 bus messages in "Remote" operation.
- iii) Corrections placed in non-volatile memory during "Autocalibration". These modify the values which control the RMS output.

After processing, the computing system changes the output of the instrument to respond to the input instructions.

Reference voltages

A 20V DC "Master" Voltage Reference establishes the fundamental accuracy of the instrument. From this 20V, a precision divider derives an adjustable "Working" reference voltage between 0.1V and 2V, whose value depends on digital inputs from front panel keys and calibration memory.

Precision Divider.

In the out-guard section the selected output value, including calibration corrections, is set into a digital comparator as a 25-bit number. This is counted out by a crystal-controlled binary

counter, resulting in a 125Hz square wave whose mark:period ratio accurately represents the output value selection. When transferred into guard, it chops the Master Reference voltage. A 7-pole active low-pass filter integrates the chopped reference, to generate the ripple-free DC Working Reference Voltage.

Quasi-Sinewave Reference Generator.

The higher accuracy of AC/AC comparison (over AC/DC), is exploited by converting the 0.1V-2V DC Working Reference into a stepped waveform whose characteristics match those of a sinewave. The amplitude of this 'Quasi-sinewave' is precisely controlled by the DC Working Reference value.

Sinewave Source

Frequency Synthesizer. From the frequency value set into the MODE / FREQUENCY display, the processor controls the synthesizer using an encoded 9-bit command. The synthesizer translates the command into a pulse train at a crystal-derived frequency between 240kHz and 4MHz, to be divided down for use as phase-reference for the quadrature oscillator.

Quadrature Oscillator. The oscillator's output frequency is set close to any demand, between 10Hz and 1MHz, by selecting the RC time constants of its dual integrators; and then by correcting to the actual demand by phase-comparison with the output from the synthesizer. The output sinewave purity and constant amplitude are precisely defined by a sophisticated control loop, and the RMS value of the sinewave is adjusted to be roughly proportional to the demanded output voltage or current. Timing data is output from the source to synchronize the actions of the Quasi-sinewave Reference Generator and AC transfer comparator.

Voltage-Controlled Error Amplifier (VCA)

This has variable gain, amplifying the output from the Sinewave Source and providing a buffered drive to the output circuits. Its gain is determined by the measured difference between the RMS values of the sensed calibrator output and the reference quasi-sinewave; so the VCA provides the correcting fine adjustment for the output amplitude loop.

Output Range Switching and Amplification

1V Range. This is the basic voltage range of the 4200. As the quasi-sinewave working reference is variable between 0.1V and 2V RMS, it is compared in 1:1 ratio with the sensed output. The 1V Buffer output is thus passed directly to the output I+ and I- terminals.

100mV, 10mV and 1mV Ranges. The 1V Buffer output is reduced by precision attenuators before being connected to the terminals, the level being sensed before attenuation.

10V, 100V and 1000V Ranges. The 1V Buffer output is amplified on each of these ranges. A separate amplifier is provided for the 10V range, the output sense signal being obtained at the terminals and attenuated before comparison with the reference. A common power amplifier is used for both 100V and 1000V ranges. On the 100V Range the output is fed directly to the terminals, on the 1000V Range the output is stepped up by a transformer. On both ranges, the sensed terminal voltage is reduced to the reference level by precision attenuators.

Output Sensing

On the 1V range and above, the output is sensed at the front panel Hi and Lo terminals. With Remote Sense selected, these are isolated from I+ and I-, but in Local Sense Hi is internally connected to I+, and Lo to I-. As described above, the 10V,

100V and 1000V ranges' sense signal is attenuated before comparison with the reference.

AC Transfer Comparator.

The comparator generates an error voltage proportional to the difference between the RMS values of the quasi-sinewave reference and the sensed output. It alternately samples a number of cycles from its 'Ref' and 'Sense' inputs, computes and integrates the squares of their instantaneous values, and uses a 'Sample and Hold' technique to subtract one from the other this being the 'error' voltage to control the VCA. The loop thus controls the 4200 output so that the RMS value of the comparator's sense input equates to that of its reference input.

Autocalibration

By setting the CAL ENABLE security keyswitch on the rear panel to ENABLE, the 4200 can be calibrated. (Refer to Section 8). The output RMS value is measured and the microprocessor is activated, to add any new corrections to factors already retained in non-volatile memory. The updated correction factors are applied in the normal RUN mode.

Processor

A 6802-series microprocessor controls the internal performance of the instrument, employing 24k bytes of program memory.

1k bytes of memory are used for stack and work space, and 1k bytes are made non-volatile by a battery-powered back-up supply, storing calibration correction factors.

With the exception of the Power ON/OFF switch and Safety Reset key, each front and rear panel control provides an input to the microprocessor system, which translates the information to command the 4200 analog and calibration functions.

The processor also controls the display, the IEEE 488 Interface Bus, and the operation of the restart and error circuitry.

Option 30 Current Output

An AC Current output is produced using a voltage to current converter, driven directly from the basic 1V range of the AC voltage section. Range selection is achieved by switching internal shunts. Over-voltage output protection is provided, and the output lines are fused. The OUTPUT display legend is altered to μ A, mA or A.



DANGER HIGH VOLTAGE



**THIS INSTRUMENT IS CAPABLE
OF DELIVERING
A LETHAL ELECTRIC SHOCK!**

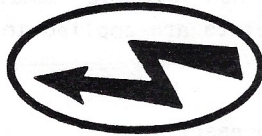

FRONT or REAR
terminals carry the
Full Output Voltage.

THIS CAN KILL!

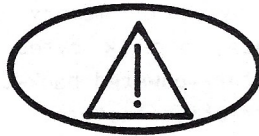

Guard terminal is
sensitive to over-
voltage

**It can damage
your instrument!**

Unless **you** are **sure** that
it is **safe** to do so,
DO NOT TOUCH the
I+ I- Hi or **Lo leads**
and **terminals**

DANGER

SECTION 2 INSTALLATION

This section contains information and instructions for unpacking and installing the Datron 4200.

Unpacking and Inspection

Every care is taken in the choice of packing materials to ensure that your equipment will reach you in perfect condition.

If the equipment has been subject to excessive mishandling in transit, the fact will probably be visible as external damage to the shipping carton. In the event of damage, the shipping container and cushioning material should be kept for the carrier's inspection.

Unpack the equipment and check for external damage to the case, sockets, keys etc. If damage is found notify the carrier and your sales representative immediately.

Standard accessories supplied with the instrument are as described in Section 1.

Preparation for Operation

DANGER

THIS INSTRUMENT IS CAPABLE OF DELIVERING A LETHAL ELECTRIC SHOCK. THE I+, I-, Hi and Lo TERMINALS ARE MARKED WITH  SYMBOL TO WARN USERS OF THIS DANGER.

UNDER NO CIRCUMSTANCES SHOULD USERS TOUCH ANY OF THE FRONT TERMINALS UNLESS THEY ARE FIRST SATISFIED THAT NO DANGEROUS VOLTAGE IS PRESENT.

Power Input.

The recessed POWER INPUT plug, POWER FUSE and Line Voltage Selector are contained in an integral filtered module at the centre of the rear panel.

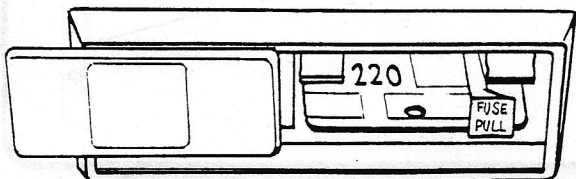

The protective window allows the fuse rating and line voltage selection to be inspected with the power socket connected. This window slides to the left once the socket has been disconnected, for access to the fuse and voltage selector printed circuit board.

Power cable

The detachable supply cable, comprising two metres of 3-core PVC sheath cable permanently moulded to a fully-shrouded 3-pin socket, fits in the POWER INPUT plug recess, and should be pushed firmly home.

The supply lead should be connected to a grounded outlet ensuring that the ground lead is connected. Connect Black lead to Line, White lead to Neutral and Green lead to Ground. (European: Brown lead to Line, Blue lead to Neutral, and Green/Yellow lead to Ground).

Line voltage.

The 4200 is operative within the line voltage ranges 100/115/120/220/230/240 $\pm 10\%$, 50 or 60Hz. To accommodate the ranges, a small PC selector board is housed beneath the POWER FUSE.

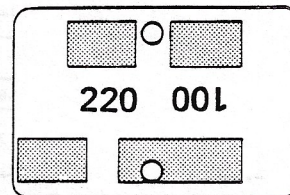
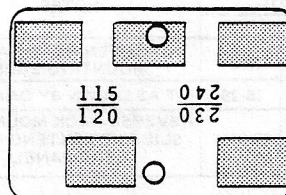

Operating Voltage Selection

FIRST ensure the POWER CABLE is removed. Slide the window to the left to reveal the fuse and PC selector board.

Draw the fuse-extractor to the left and remove the fuse.

Remove the PC selector board and rotate until the desired voltage is on the left side of the upper surface.

Reinsert the selector board firmly into the module slot. The desired voltage is visible in the cut-out below the fuse.

Return the fuse extractor to the normal position.

Insert the appropriate POWER FUSE (see over).

Slide the window to the right and insert the POWER CABLE.

Power Fuse

The fuse rating is:

3.15A for 220/240V line supply

6.25A for 100/120V line supply

It is located behind the window in the POWER INPUT module on the rear panel, and should be of the anti-surge or SLO BLO type.

WARNING

MAKE SURE THAT ONLY FUSES WITH THE REQUIRED RATED CURRENT AND OF THE SPECIFIED TYPE ARE USED FOR REPLACEMENT. THE USE OF MENDED FUSES AND THE SHORT CIRCUITING OF FUSE-HOLDERS SHALL BE AVOIDED, AND RENDERS THE WARRANTY VOID.

Bench Mounting

The instrument is fitted with six rubber-covered plastic feet. It is intended to stand flat on a bench, positioned so that the cooling-air inlet and exhaust apertures are not obstructed. It is recommended that at least 30cms (12 inches) of free space is at the rear.

Rack Mounting

Option 90 permits the instrument to be mounted in a standard 19 inch cabinet.

To Fit Option 90

CAUTION

Note that the 4200 is designed to be supported at front and rear. AT NO TIME should the 4200 be supported only by the front brackets. On no account should the upper and lower covers be removed.

Remove the two rear spacers from the case sides by releasing six screws. Fit the two-rack mounting slides to the rear of the case sides and secure using six of the shorter screws in the option kit.

N.B The slides may be reversed to give rearward extension.

Fit the two front rack-mounting ears to the rear of the cabinet, with tongues facing forward. In shallow cabinets it may be necessary to trim the tongue.

CAUTION

Assistance is required to fit the 4200 into the cabinet.

Lift the 4200 into position in the cabinet, locate the tongues in the slides, and carefully slide backwards until the front ears butt up against the cabinet front. Secure the front ears to the cabinet. Also clear ventilation for fan cooling to operate properly.

SUITABLE RACK DEPTHS

DEPTH		NOTES
mm	ins	
< 635	< 25	SHORTEN REAR RACK MOUNTING EARS
635-735	25-29	FIT AS SHOWN BY DRAWING
735-800	29-31½	REVERSE RACK MOUNTING SLIDES TO EXTEND PAST REAR PANEL

①

REMOVE

2 OFF 450300 REAR SPACERS
6 OFF 611038 M4X12mm SOCKET HD CSK SCREWS

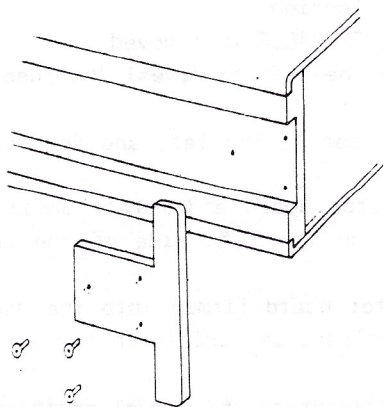

②

FIT AS INSTRUCTED

2 OFF 450312 RACK MOUNTING EAR FRONT
2 OFF 450313 RACK MOUNTING EAR REAR
2 OFF 450314 RACK MOUNTING SLIDE
12 OFF 611062 M4X8mm SOCKET HD CSK SCREWS

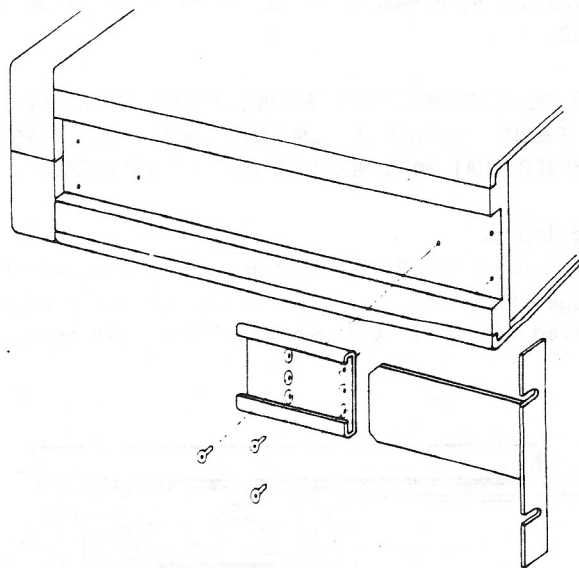

Rack Mounting — Fitting of Option 90

Connectors and Pin Designations

IEEE 488 Input/Output Socket J27.

The IEEE input/output is a 24-way connector that is directly compatible with the IEEE 488 interface and the IEC 625 Bus.

Pin Layout.

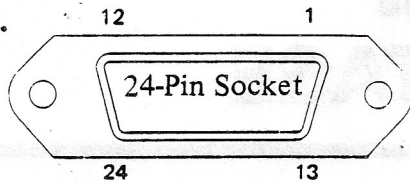

Pin Designations

J27 Pin No	Name	Description
1	DIO 1	Data Input Output Line 1
2	DIO 2	Data Input Output Line 2
3	DIO 3	Data Input Output Line 3
4	DIO 4	Data Input Output Line 4
5	EOI	End or Identify
6	DAV	Data Valid
7	NRFD	Not ready for Data
8	NDAC	Not Data Accepted
9	IFC	Interface Clear
10	SRQ	Service Request
11	ATN	Attention
12	SHIELD	Screening on cable (connected to 4200 Safety Ground)
13	DIO 5	Data Input Output Line 5
14	DIO 6	Data Input Output Line 6
15	DIO 7	Data Input Output Line 7
16	DIO 8	Data Input Output Line 8
17	REN	Remote Enable
18	GND 6	Gnd wire of twisted pair with DAV
19	GND 7	Gnd wire of twisted pair with NRFD
20	GND 8	Gnd wire of twisted pair with NDAC
21	GND 9	Gnd wire of twisted pair with IFC
22	GND 10	Gnd wire of twisted pair with SRQ
23	GND 11	Gnd wire of twisted pair with ATN
24	GND	4200 Logic Ground (Internally connected to 4200 Safety Ground)

REAR OUTPUT TERMINALS

The 4200 is fitted with either six front panel output terminals or six rear output terminals. The Rear Output alternative is fitted at the customer's request only at manufacture.

Socket J53 External Reset.

This D-type plastic socket is located next to the cooling air intake filter. It may be used to input an external reset to restore the 4200 to its power-up state of ACV, 10V range etc. if required.

Pin Layout

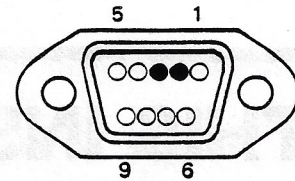

Pin Designation

J53 Pin No	SIGNAL
1	Not used
2	Reset Common
3	Reset line
4-9	Not used

External Reset Switch Wiring

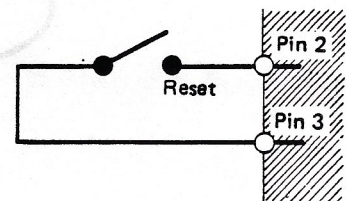

The functions of the six terminals are identical to those normally fitted on the front panel, and the external leads are connected in the same way (See Section 4 for details).



DANGER HIGH VOLTAGE



**THIS INSTRUMENT IS CAPABLE
OF DELIVERING
A LETHAL ELECTRIC SHOCK!**

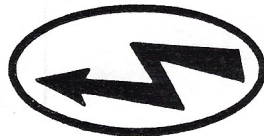

FRONT or REAR
terminals carry the
Full Output Voltage.

THIS CAN KILL!



Guard terminal is
sensitive to over-
voltage

**It can damage
your instrument!**

Unless **you** are **sure** that
it is **safe** to do so,
DO NOT TOUCH the
I+ I- Hi or Lo leads
and **terminals**

DANGER

SECTION 3 OPERATING CONTROLS

This section summarizes the main operating features of the 4200. For detailed operating procedures refer to Section 4.

Front Panel Power-up state

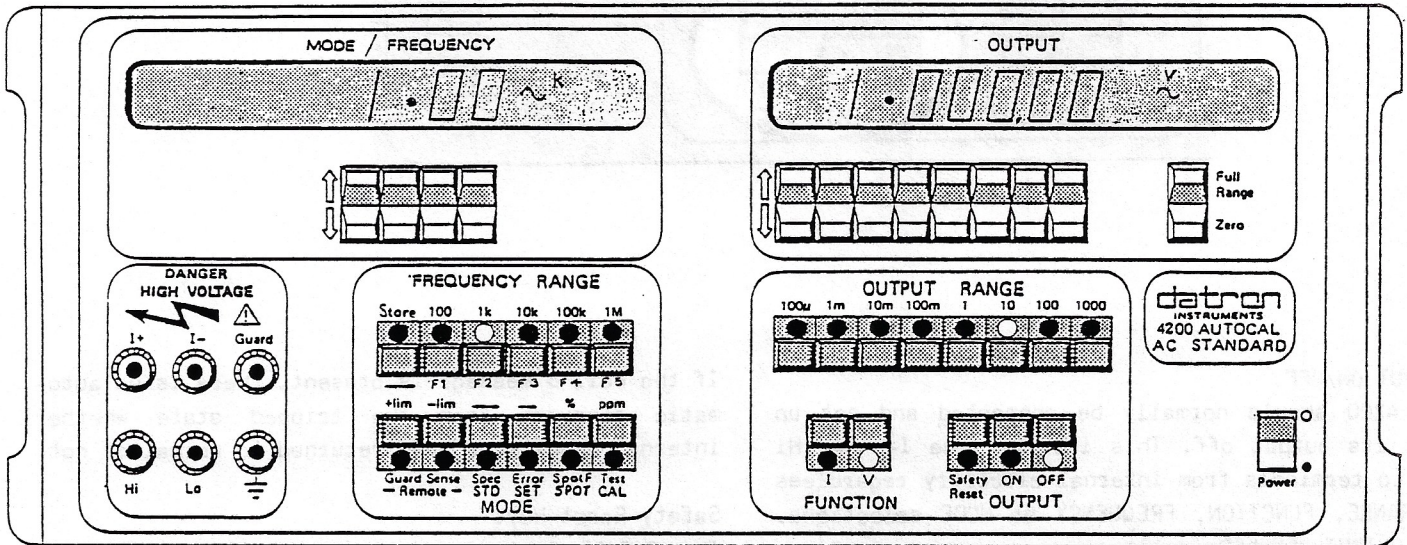

The controls are outlined in blocks, left and right, associated with the appropriate display. The right-hand blocks generally deal with function and output definition, whereas the left-hand blocks are concerned with frequency, mode and terminal configurations.

Front Panel Keys

All user commands from front panel keys (except Safety Reset) are executed through main program firmware. A Key LED lit signifies that conditions are valid for the selected operation, and not merely that the key has made contact.

At any time, the instrument status is described by the combination of LED states, display values and display messages.

Generally, if an invalid condition is selected, either the nearest valid condition is activated, or the command is ignored and the 4200 remains in its previous state.

Power Switch

WARNING

THE POWER SWITCH SHOULD NOT BE SET TO ON UNTIL THE LINE VOLTAGE AND POWER FUSE RATING HAVE BEEN SELECTED AS DETAILED IN SECTION 2 (INSTALLATION)

When set to the (OFF) position, the 2-pole Power switch isolates the instrument from the supply.

When switched to (ON) the instrument powers up, runs a self-test program and is configured into the following state:

OUTPUT	OFF
FUNCTION	V
OUTPUT RANGE	10
OUTPUT DISPLAY	1.000,00 \sim V
FREQUENCY RANGE	1kHz
MODE/FREQUENCY DISPLAY	1.00 \sim k
MODES	Not selected
Guard	Local connection
Sense	Local connection
Key LEDs Lit	OUTPUT OFF, V, 10, 1k

OUTPUT Switching

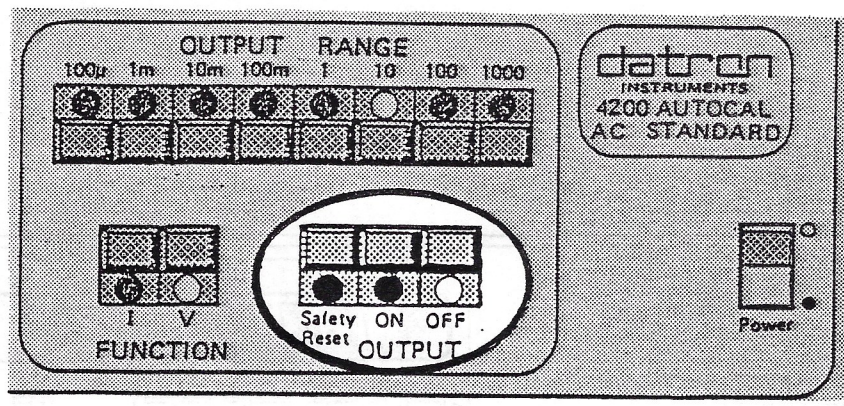

OUTPUT ON/OFF.

The 4200 should normally be connected and set up with its output off. This isolates the I+, I-, Hi and Lo terminals from internal circuitry regardless of RANGE, FUNCTION, FREQUENCY or MODE selections. The OUTPUT OFF LED is lit.

Pressing the OUTPUT ON key connects the I+, I-, Hi and Lo terminals to their energised internal circuits.

OUTPUT OFF Default.

Certain instrument states are prohibited, and some transfers between states are restricted by program firmware. For safety reasons some of these transfers result in the output being switched off. Refer to section 4, Operating Routines.

OUTPUT OFF Trip - Fail 5 Message.

Under certain abnormal conditions which might compromise safety the 4200 output will trip off, accompanied by a Fail 5 message on the MODE display. Control is removed from the front panel keys.

If the Fail 5 message is present, there is no automatic recovery from the tripped state whether internal conditions have returned to normal or not.

Safety Reset key.

The Safety Reset key allows a user to reset the safety trip to test whether conditions have returned to normal. If they have; the Fail message will disappear, the previous instrument state will be restored but with output off, and front panel control will be returned to the user. If conditions are still abnormal the Fail state will persist, and a further attempt may be made after a suitable interval. The Safety Reset LED is inoperative except in "Test" mode.

Other Messages

A full list of 4200 messages appears in Section 4. The fault conditions which generate Fail messages are analysed in the Calibration and Servicing Handbook.

FUNCTION Keys

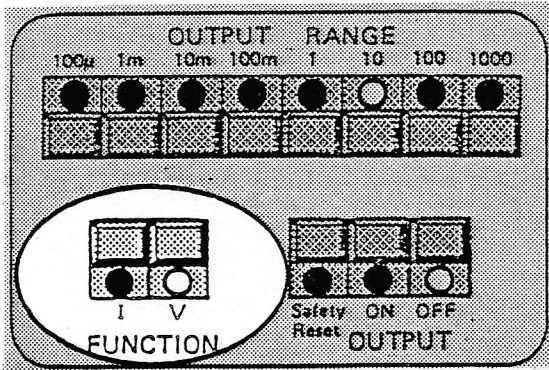

Selected Function	Specified Output
V	AC Voltage
I	AC Current

When changing from one function to another the output is automatically set to OFF, and frequency defaults to 1kHz.

If the corresponding OUTPUT RANGE is not available on the new function, the 4200 selects the closest to it.

The numeric value of output is translated into the corresponding value on the new function and range.

e.g: If set to 135µA on 100µA Range when V is pressed, an output value of 1.35mV on the 1mV Range will be selected.

OUTPUT RANGE Keys

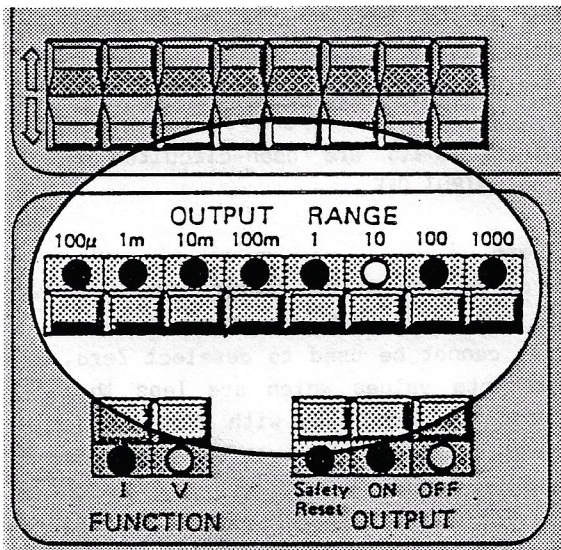

Each OUTPUT RANGE key scales the output as selected by the user, setting the legend and decimal point on the OUTPUT display to match. Full range values are marked above the keys.

AC Voltage Ranges are selectable from 1mV to 1000V RMS, and AC Current from 100µA to 1A RMS, the actual output value being selected by use of the OUTPUT display ↑ / ↓ keys.

If OUTPUT is ON when changing ranges, it remains on unless the change is to 1000V range, or ranging-up to more than 75V on 100V range. In these cases OUTPUT defaults to OFF. Any range selection which would exceed the internally defined voltage-frequency limit is automatically inhibited. These limits are described on page 3-6.

Key Selections	100µ	1m	10m	100m	1	10	100	1000
Voltage Ranges	(1mV)	1mV	10mV	100mV	1V	10V	100V	1000V
Current Ranges	100µA	1mA	10mA	100mA	1A	(1A)	(1A)	(1A)

OUTPUT Display and ↑/↓ Keys

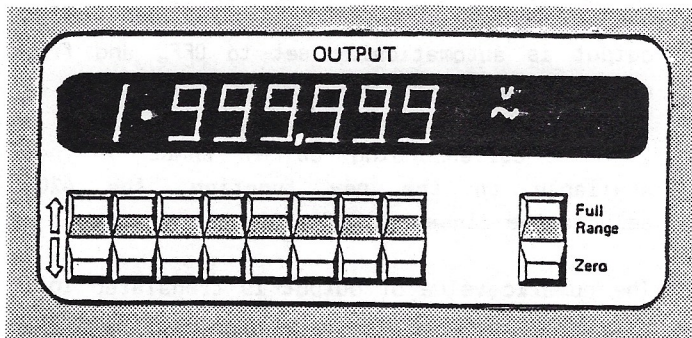

Display Resolution.

The 4200 AC Voltage and Current Outputs are resolved to $6\frac{1}{2}$ digits on all ranges. The OUTPUT display reflects this resolution; $6\frac{1}{2}$ digits are available on all ranges. The OUTPUT display is supplemented by legends, which always indicate the correct units for the range and function selected.

Output and Display Control.

Each vertical pair of ↑/↓ keys is assigned to the display digit above it. Thus the value registered on the display may be set within the range permitted by the function selected. Each momentary press of the ↑ key adds 1 to its digit; pressing the ↓ key subtracts 1. If OUTPUT is ON, the Output terminal value is also changed by the same increments as the display (subject to the instrument interlocks).

Auto-Increment/Decrement.

When an ↑/↓ key is pressed for more than $\frac{1}{2}$ second, its digit is increased or decreased at a rate of approximately 3 digits per second until the key is released.

Overflow and Underflow.

As a digit is stepped from 9 to 0, the value of the next higher-order digit is increased by 1. Stepping from 0 to 9 decreases the value by 1. The whole display therefore acts as a counter, with full "carry" and "borrow" action.

Range of Adjustment.

The ↑/↓ keys adjust the reading between a minimum of 0090000 (9% of Nominal Range), and maximum of 1999999 Full Scale on 100mV - 100V and Current Ranges. The 1000V Range has a Full Scale of 1100.000; the 1mV and 10mV ranges are truncated.

Leading Zeros.

For fractional readings, a leading zero is presented to the left of the decimal point to emphasize its position, except for OUTPUT RANGE selections 1m and 1.

Full Range key

When the Full Range key is pressed, the display reverts to the nominal value of the range selected. If OUTPUT is already ON, the terminal value follows the display value unless:

1. The combination of output voltage and frequency would exceed the instrument's internally defined limits. (refer to Section 6).
2. Error Mode is selected: The user-input gain error is not cancelled from the output.

Zero key

This reduces the display value to zero. If OUTPUT is ON, the terminal value is also set to zero:
Voltage - an internal hard-wired short is connected across the Hi, Lo, I+ and I- terminals.
Current - output terminals are open-circuited by setting OUTPUT OFF.

Deselection of Zero.

The size of the characters on the "Zero" display is significant. A half-size "o" above any ↑/↓ key indicates that it cannot be used to deselect Zero, because it increments values which are less than 10% of nominal range. Any ↑ key with a full-size "0" above it (and any key to its left) deselects Zero and adds its increment.

Lower-order Digit Suppression.

Unless Error Mode is selected, the user may reduce the resolution of the display by removing unwanted lower-order digits using one ↑/↓ key and the Zero Key. The method is described in Section 4.

Selection of High Voltage Outputs.

The 4200 is capable of delivering LETHAL output voltages so program interlocks are used to ensure that users do not inadvertently select outputs in excess of 75VRMS.

Details of the High Voltage selection procedure are given in Section 4.

Frequency

The output of the 4200 extends from 10Hz to 1MHz in five overlapping decade ranges, at a resolution of 1% of nominal Frequency Range. Any five frequency values within the range of the instrument can be stored in volatile memory. Also, five 'Spot Calibration' frequency values for each Voltage and Current Output Range may be stored in non-volatile memory during calibration, with associated high-accuracy calibration constants.

FREQUENCY RANGE keys

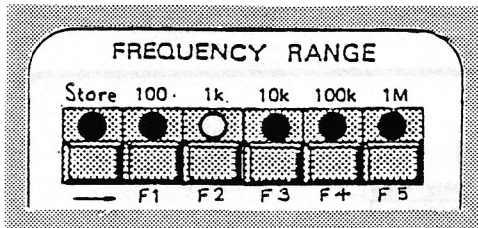

Decade Ranging.

Generally, selection of a new range changes the frequency by a whole number of decades; but ranging-up from a frequency between 10Hz and 30Hz selects the lowest frequency in the new range. Also, ranging-up to the 1MHz range defaults to the range-maximum of 1MHz if the decade frequency would have been higher.

Selection of Nominal Range Value.

Once a Frequency Range has been selected, it can be set to its nominal value by re-pressing its key.

FREQUENCY Display

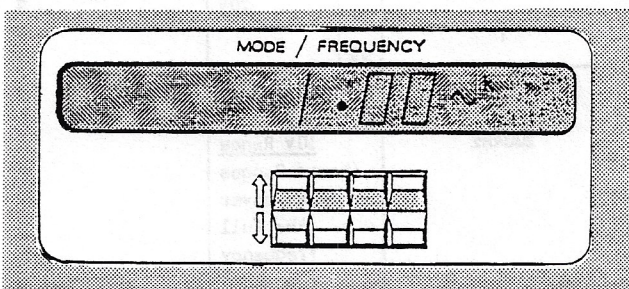

Resolution.

The output frequency is adjustable in steps of 1% of the selected FREQUENCY RANGE nominal value, matching the display resolution. Legends are appended on the display as appropriate, and a leading zero is presented to the left of the decimal point for fractional values.

FREQUENCY ↑/↓ Control Keys.

Each vertical pair of ↑/↓ keys is assigned to the display digit above it. The frequency registered on the display is adjusted by manipulation of these keys. Each momentary press of the ↑ key adds 1 to its digit, and each ↓ key subtracts 1. If OUTPUT is ON, the output frequency is also changed by the same increments as the display (subject to the instrument interlocks). Keys below decimal points are inactive.

Auto-Increment/Decrement.

When a ↑/↓ key is pressed for more than ½ second its digit is increased or decreased at a rate of approximately 3 digits per second until the key is released.

Overflow and Underflow.

As a digit is stepped from 9 to 0, the value of the next higher-order digit is increased by 1. Stepping from 0 to 9 decreases the value by 1. The whole display therefore acts as a counter, with full "carry" and "borrow" action.

Autoranging.

Stepping the frequency beyond the span of a range automatically switches range up or down, but further steps are inhibited until the ↑ or ↓ key is released (the key could be below a decimal point). When the range-change occurs, the alarm buzzer sounds and the FREQUENCY display is blanked for approx. 1 second.

When the display is reinstated, the 4200 has remembered the last frequency on the old range, and sets the new range to its next incremental frequency in the original direction. After releasing the original key, stepping can be continued in any increments of the new range.

Autorange Limits.

The 4200 ignores any increment or decrement which would select a frequency outside the limits of the next range up or down (also accounting for FUNCTION and OUTPUT RANGE selections - See Page 3.6).

OUTPUT/FREQUENCY CONSTRAINTS

Voltage and Frequency

Under most conditions, the output amplitude and frequency are adjustable throughout their full scales:

- Voltages - from 90 μ V to 1100V
- Frequencies - from 10Hz to 1MHz.

On the 100V and 1000V Ranges, certain combinations of voltage and frequency cannot be selected. The diagram below illustrates the boundaries. The 10V Range span is also shown for comparison.

The 4200 refuses to select any Voltage/Frequency combination outside these constraints. The temporary message Error 7 is displayed for 3 seconds before reverting to the original display.

Current and Frequency.

Current is adjustable between 9 μ A and 2A RMS at frequencies from 10Hz to 5kHz (all Current Ranges have the same span). Error 7 indicates an invalid Current/Frequency selection.

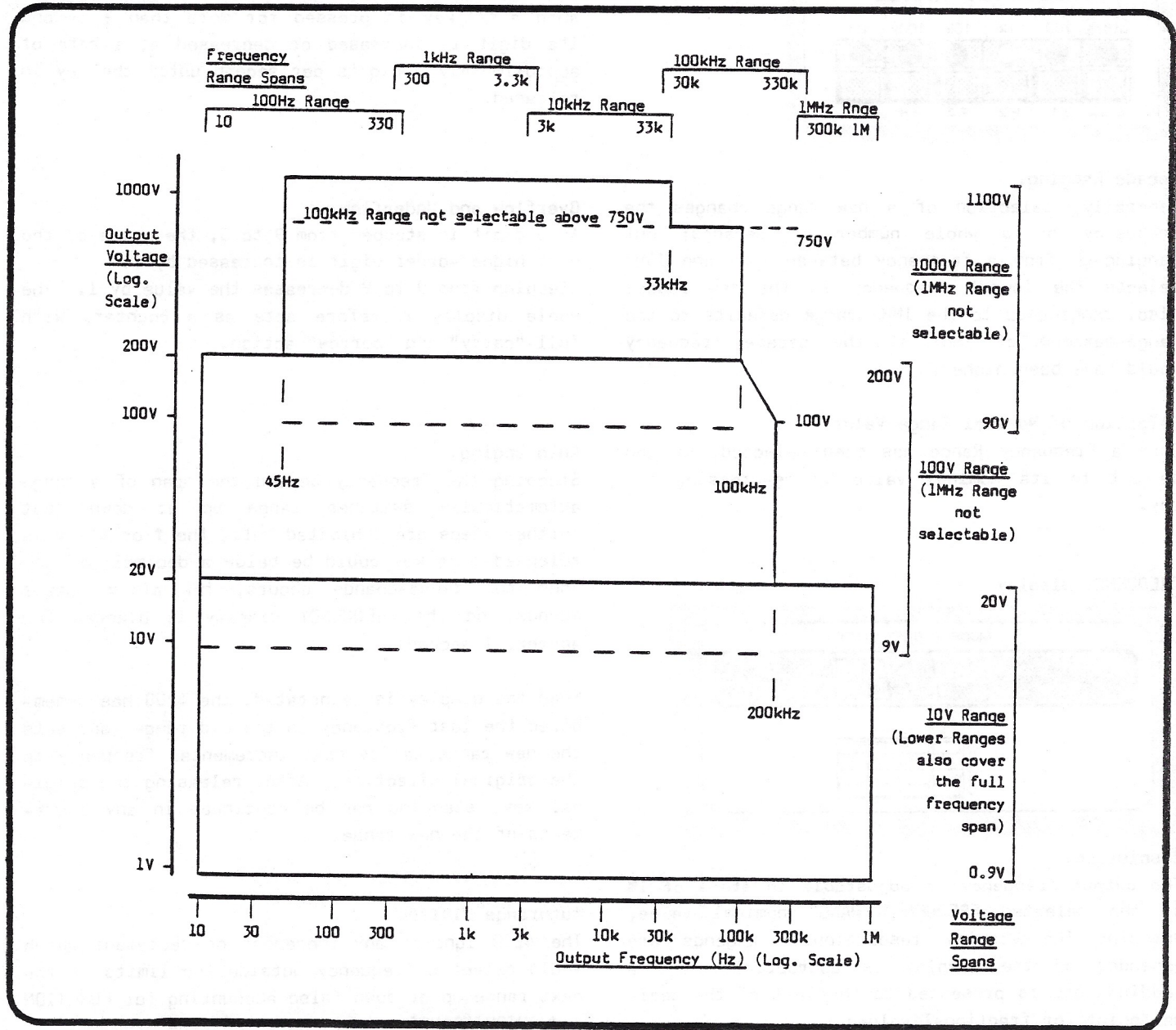

FREQUENCY MEMORY

This facility allows storage of up to five user-selected frequencies. Once stored, each can easily be retrieved or changed from the front panel. They are retained until power is removed from the instrument.

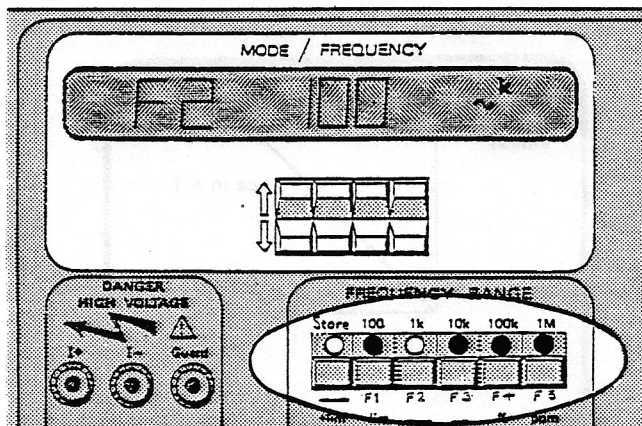

Store key.

Only five of the FREQUENCY RANGE keys select ranges. The first press of the sixth key, Store, reassigns the other five as frequency memories. It has toggle action: a second press deselects the memory function, and the frequency defaults to 1kHz.

F1-F5 Memory keys.

When the Store LED is ON, these keys select individual memory locations.

NB. Although the FREQUENCY RANGE keys double as memory selectors, this does not imply that a particular memory can only accept frequencies from its key's range. It is emphasized that any displayable frequency can be stored in any of the five locations.

Power-up Default.

Because the stores are volatile, the following default frequencies are stored in the five memory locations each time the 4200 is powered-up.

F1	30Hz
F2	300Hz
F3	3kHz
F4	30kHz
F5	300kHz

Details of storage and retrieval procedures are described in Section 4.

SPOT F FREQUENCY MEMORY

When in Calibration Mode, five user-selected "Spot" frequencies can be stored in the non-volatile calibration memory, for each of the seven Output Ranges. At these frequencies the 4200 output can be specially Autocalibrated. Each can then be subsequently recalled when in Run Mode by two key depressions.

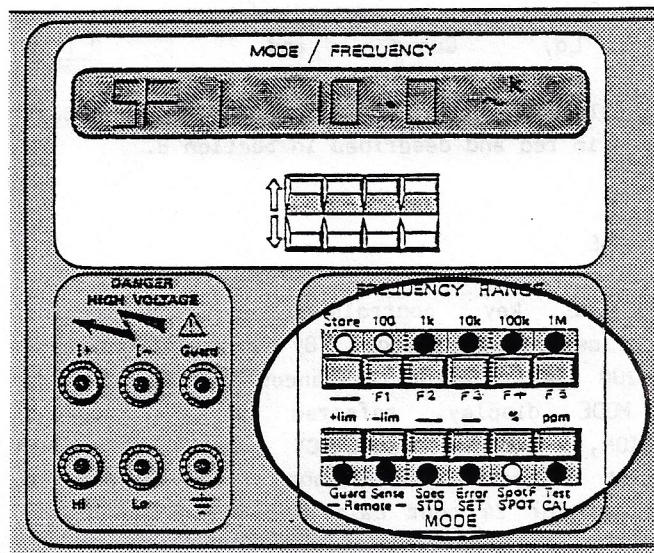

Spot F (SPOT) key.

This is used to reassign the F1-F5 memory keys so that they access the non-volatile memory.

"Recall" procedures are detailed in Section 4.
"Store" procedures are detailed in Section 8.

MODE Selection Keys

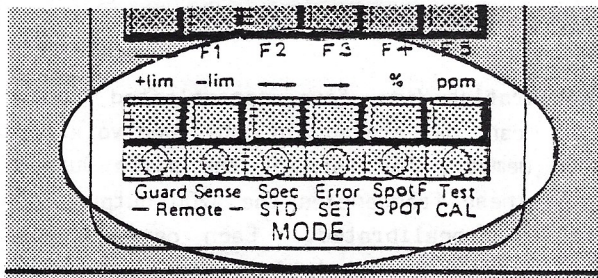

The MODE selection keys are located on the lower left of the front panel. The Remote Guard and Remote Sense keys are described under "I+, I-, Hi, Lo, Guard and "⏏".

STD, SET, SPOT and CAL are calibration modes, printed in red and described in Section 8.

SPEC MODE

The Spec key controls the toggle-action "Specification" function. By pressing the key, the 4200 specification tolerances are displayed on the MODE display, referred to its current FUNCTION, OUTPUT, FREQUENCY and CALIBRATION INTERVAL selection. A second press cancels the function. For 24 hour calibration intervals, the "Stability" figures are displayed (valid only if the environmental conditions are identical to those at calibration), but for 90 days and 1 year intervals they are "Traceable" accuracy figures which include Datron's Calibration Uncertainty.

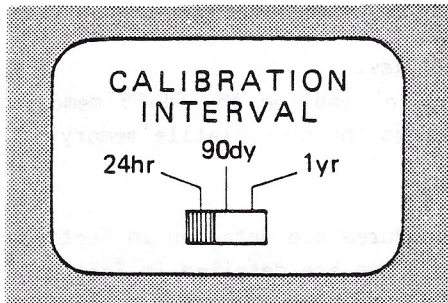

Rear Panel CALIBRATION INTERVAL switch

While in Spec mode, all primary functions of the other MODE keys are cancelled (although the selected Guard and Sense connections remain). The keys are reassigned to their secondary functions: +lim, -lim, % and ppm become active. When Spec mode is initiated, the magnitude of the specification tolerance itself determines whether ppm or % is selected. The arrow \longleftrightarrow above the Spec key shows that all four secondary modes are available.

Full details of the operation of Specification mode are given in Section 4.

ERROR MODE

This key is used to deviate the output at the terminals from the value on the OUTPUT display.

Error Mode NOT Selected.

The terminal value is a linear function of the OUTPUT DISPLAY value:

$$\text{Terminal value} = (m \times \text{OUTPUT DISPLAY value}) + c$$

where $m = 1$ and $c = 0$.

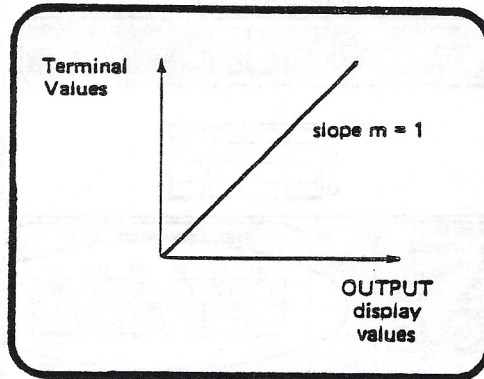

Error mode selected.

In Error mode, the slope (m) can be adjusted within 10% of the displayed value (see the figure below). To increase resolution, ppm may be selected for deviations below 0.1%.

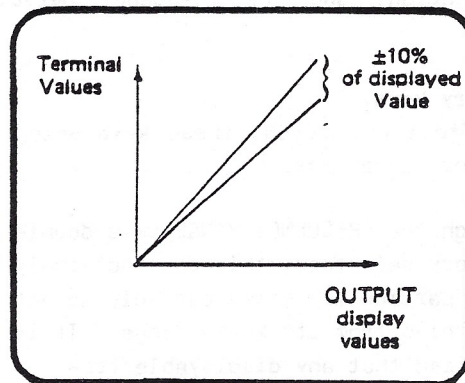

Full details of the operation of Error mode are given in Section 4.

SPOT F AND TEST MODES

Spot F mode selected.

A description of Spot F mode is given on page 3-7. Full operating details appear in Section 4.

Test mode selected.

Full details of the operations in Test mode are given in Section 4.

I+, I-, Hi, Lo, Guard and \perp (Ground) Terminals

Local and Remote Switching.

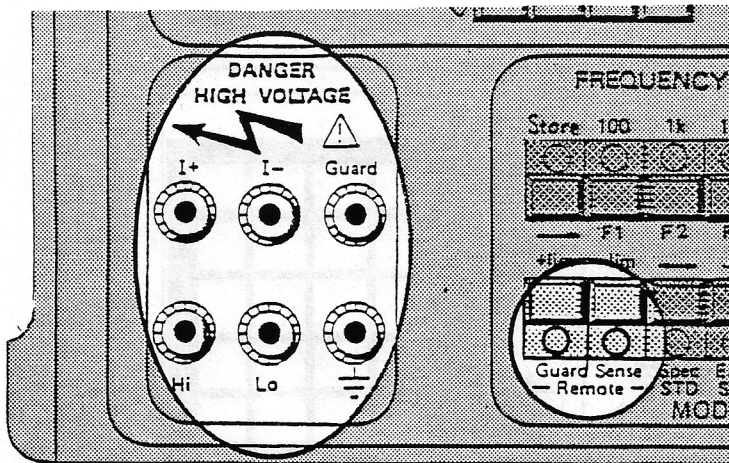

These terminals are located on the lower left of the Front Panel.

I+ and I- Terminals.

The output from the internal power circuits is delivered to the I+ terminal, I- being its Return Analog Common.

Hi and Lo Terminals.

The Hi terminal is used to sense the output voltage, Lo is the Sense Analog Common. To obtain specified RMS outputs, the sense loop must always be completed.

Remote Sense.

The Remote Sense key has "toggle" action. Successive presses alternate between ON and OFF.

N.B. Sense connections can only be switched with OUTPUT OFF.

The specified RMS voltage output of the 4200 may be produced either at its output terminals (Local Sense for high impedance loads) or at the load terminals (Remote Sense for cases in which lead resistance and load impedance produce a significant effect).

With Remote Sense OFF, the Hi and Lo terminals are internally connected to the I+ and I- terminals.

With Remote Sense ON, the output voltage must be sensed externally, using leads connected to the Hi and Lo terminals.

Remote Sense is not available on 1mV - 100mV ranges. It is not applicable to Current outputs.

Guard Terminal.

The Guard terminal is permanently connected to the internal guard shields:

Remote Guard.

The Remote Guard key has "toggle" action. Successive presses alternate between ON and OFF.

With Remote Guard OFF, Guard is internally connected to the I- terminal.

With Remote Guard ON, the internal link to I- is removed. The Guard terminal can then be connected externally to reduce common mode interference.

Ground Terminal.

The \perp (Ground) terminal connects directly to the 4200 internal Ground shields and to Safety Ground via the power-cable.

Output Connections.

Connections to the output terminals may be made either with leads or via a shrouded connector.

For AC Voltage outputs in local sense the two leads should be attached to the Hi and Lo terminals.

Various configurations of 4200 load connections are detailed in Section 4.

Rear Panel (Shown with alternative Rear Output terminals).

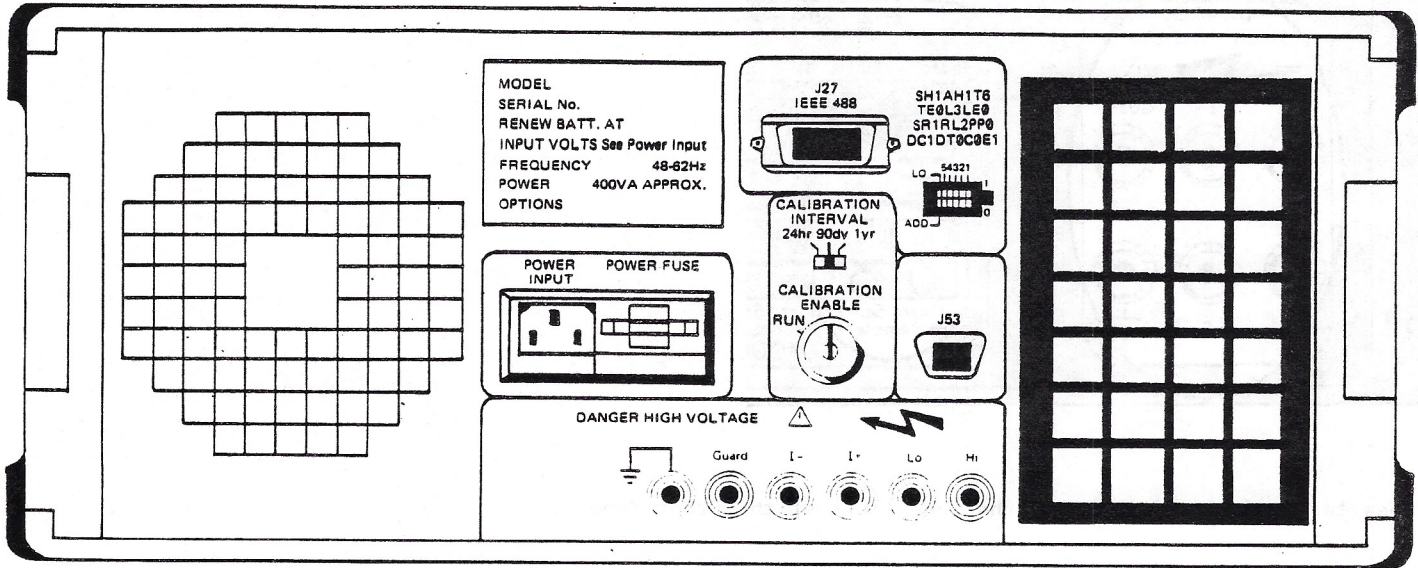

POWER INPUT

The recessed power input plug, power fuse and line voltage selector are located in the centre of the rear panel, contained within a single moulded unit. Details of connections, selection of line voltage and fuse are given in Section 2.

REAR OUTPUT ALTERNATIVE

This can be incorporated at manufacture, to provide six output terminals on the rear panel instead of the six on the front. Their functions and connections are identical.

SOCKET J53 (External Reset)

This D type plastic socket is located next to the cooling air intake filter. It may be used to input an external reset to restore the 4200 to its power-up state of ACV, 10V Range etc. if required. Pin Layout, Pin Designation and Switch Wiring details are given in Section 2.

SOCKET J27 (IEEE 488 Input/Output)

The IEEE 488 Input/Output (D-type) socket J27 is a 24-way micro-ribbon connector that is directly compatible with the IEEE 488 interface and the IEC-defined system.

J27 is located at the top of the rear panel, outlined with the IEEE 488 address switch. The pin layout and designations appear in Sections 2 and 5.

IEEE 488 ADDRESS SWITCH

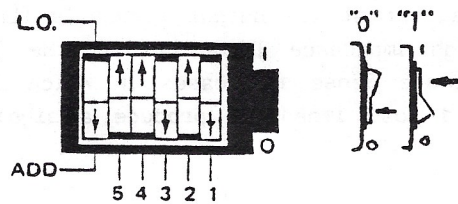

The 4200 may be addressed for use on the IEEE 488 interface bus. The address settings are given in Section 5.



DANGER HIGH VOLTAGE



**THIS INSTRUMENT IS CAPABLE
OF DELIVERING
A LETHAL ELECTRIC SHOCK!**

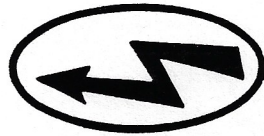

FRONT or REAR
terminals carry the
Full Output Voltage.

THIS CAN KILL!

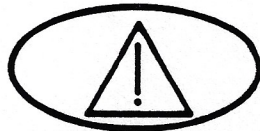

Guard terminal is
sensitive to over-
voltage

**It can damage
your instrument!**

Unless **you** are **sure** that
it is **safe** to do so,
DO NOT TOUCH the
I+ I- Hi or Lo leads
and **terminals**

DANGER



WARNING
HIGH VOLTAGE



THIS INSTRUMENT IS CAPABLE
OF DELIVERING
A LETHAL ELECTRIC SHOCK

PRINTED IN U.S.A.
MADE IN U.S.A.



THIS CASE KILLS

WARNING
DO NOT TOUCH
INTERNAL PARTS



INTERNAL PARTS
FROM DAMAGE
(Instrument only)

DO NOT TOUCH
INTERNAL PARTS
OR YOU WILL BE
KILLED

WARNING

SECTION 4 USING THE DATRON 4200

Preliminaries

Before using the instrument it is important that it has been correctly installed as detailed in Section 2.

Limiting Characteristics

The following details are given in Section 6.

Function	Characteristics
All functions	Peak terminal voltages
AC Voltage	Output resistance and current limit
AC Current	Maximum load resistance and maximum compliance

SAFETY

The 4200 is designed to be Class 1 equipment as defined in IEC Publication 348 and UL 1244, concerning safety requirements.

Protection is provided by a direct connection via the power cable from ground to exposed metal parts and internal ground screens.

The line connection must only be inserted in a socket outlet provided with a protective ground contact, and continuity of the ground conductor must be assured between the socket and the instrument.

WARNING:

ANY INTERRUPTION OF THE PROTECTIVE GROUND CONDUCTOR INSIDE OR OUTSIDE THE INSTRUMENT OR DISCONNECTION OF THE PROTECTIVE GROUND TERMINAL MAY MAKE THE APPARATUS DANGEROUS. INTENTIONAL INTERRUPTION IS PROHIBITED.

THE TERMINALS MARKED WITH THE  SYMBOL CARRY THE OUTPUT OF THE 4200. THESE TERMINALS AND ANY OTHER CONNECTIONS TO THE LOAD UNDER TEST COULD CARRY LETHAL VOLTAGES.

UNDER NO CIRCUMSTANCES SHOULD USERS TOUCH ANY OF THE FRONT (OR REAR) PANEL TERMINALS UNLESS THEY ARE SATISFIED THAT NO DANGEROUS VOLTAGE IS PRESENT.

Caution:

The  symbol is used to remind the user of special precautions detailed in this Handbook and is placed adjacent to terminals that are sensitive to overvoltage conditions.

Refer to Section 6.

Interconnections

IMPORTANCE OF CORRECT CONNECTIONS

The 4200 has been designed for use as an accurate source for precision calibration. To match the external circuitry to its superior specification, it is essential to take great care in making connections to the load.

SOURCES OF ERROR

Thermal EMFs

These can give rise to series (Normal) mode interference, particularly for low voltage outputs, and where large currents have a heating effect at thermo-electric junctions. Draughts can cause unbalanced cooling in an otherwise thermo-electrically balanced measuring circuit.

E-M Interference

Noisy or intense electric, magnetic and electromagnetic effects in the vicinity can disturb the measurement circuit. Some typical sources are:

- Proximity of large static electric fields.
- Fluorescent lighting.
- Inadequate screening, filtering or grounding of power lines.
- Transients from local switching.
- Induction and radiation fields of local E-M transmitters.
- Excessive common mode voltages between source and load.

The disturbances may be magnified by the user's hand capacitance. Electrical interference has greatest effect in high impedance circuits. Separation of leads and creation of loops in the circuit can intensify the disturbances.

Lead Impedance

The impedance of the connecting leads can drop significant voltages between the source and load, and generate adverse phasing effects particularly if the leads are long or the current in them is high.

Lead Insulation Leakage

This can cause significant errors in measurement circuits at high voltages. Some insulating materials suffer greater losses than others e.g. PVC has more leakage than PTFE.

AVOIDANCE TACTICS

Thermal EMFs:

Screen thermal junctions from draughts. Allow time for thermal equilibrium to be reached before taking readings.

Use conductors, joints and terminals with a good margin of current-carrying capacity.

Avoid thermoelectric junctions where possible:

e.g. Use untinned single-strand copper wire of high purity. Avoid making connections through Nickel, Tin, Brass and Aluminium. If oxidation is a problem use gold-plated copper terminals, and replace the terminals before the plating wears off. If joints must be soldered, low-thermal solders are available, but crimped joints are preferred. Use low-thermal switches and relays where they form part of the measuring circuit.

Balance one thermal EMF against another in opposition, where possible. (Switch and relay contacts, terminals etc.)

E-M Interference:

Choose as "quiet" a site as possible (a screened cage may be necessary if interference is heavy). Suppress as many sources as possible.

Always keep interconnecting leads as short as possible, especially unscreened lengths.

Run leads together as twisted pairs in a common screen to reduce loop pick-up area, but beware of leakage problems and excessive capacitance.

Where both source and load are floating, connect I- to ground at the source to reduce common mode voltages.

Lead Impedance:

Keep all leads as short as possible. Use conductors with a good margin of current-carrying capacity. Use Remote Sense and 4-wire connections where necessary to establish the 4200 output specification at the load.

Lead Insulation Leakage:

Choose low loss insulated leads - PTFE is preferred to PVC.

When running leads together in screened pairs, avoid large voltages between leads in the same screen, especially if using PVC insulation.

Remote / Local Sense Configurations

The 4200 terminals are configured as follows:

Voltage Ranges:

- 1mV, 10mV, 100mV - Local Sense only
- 1V, 10V, 100V, 1000V - User selects Local or Remote Sense.

Current Ranges: - Not applicable.

The key LED indicates) - Lit = Remote
the true connexion) Unlit = Local

4200 - CONNECTIONS TO THE LOAD

General Considerations.

The choice of connection method is influenced by several factors:

a. Loading Effects

4-wire connections should be used for low load impedances. For high impedance loads, 2-wire connections can be employed.

The ratio : $\frac{\text{Total Lead Resistance}}{\text{Load Resistance}}$

gives the approximate error for 2-wire connexion at low frequencies.

e.g. Two $\frac{1}{2}$ -Ohm leads with a load of 100kOhms produce an error of approx. 10ppm.

At frequencies higher than about 100kHz, the error is also modified by reactive effects.

b. Noise and Output Level

Providing the E-M environment is reasonably quiet, interference due to noise pickup in the load connection is insignificant for outputs of more than about 100mV, so unscreened leads can be used. But at lower signal levels, or in noisier environments, it is advisable to use screened cable.

c. Common Mode Disturbances.

When in Local Guard, the guard shields and tracks for the Sense circuitry are connected internally to "I-", the low impedance terminal of the 4200 output power source. This classical connection effectively guards-out internal common mode disturbances. To reduce external disturbances it is advisable to make only one ground connection to the measurement circuit, and in the case of a guarded DMM, to make use of its external guard facilities. Also, where a line-powered load (such as a DMM being calibrated) has a ground connection, it should be to the same line ground as the 4200.

d. High Frequency Effects.

i. Voltage. Up to about 100kHz, for outputs above 100mV, it is possible to use pairs of unscreened wires, provided that the E-M environment is quiet. Leads should be less than 1 meter long, twisted or running together.

Above 100kHz, both lead and load capacitances reduce the load impedance. Similarly, lead and load inductances combine to increase the load impedance with frequency (but heavily reactive loads should be avoided). It is therefore advisable to make leads from low-capacitance coaxial or twin-axial cable. To avoid mutual coupling, Sense and Power leads should not run together within the same screen.

ii. Current. Above about 1kHz, with low output currents, high lead capacitance can introduce shunt errors. To reduce these errors, the leads should be kept as short as possible, and be of low-capacitance.

e. DANGER.

The 4200 output circuits are not internally connected to Ground. Users are **STRONGLY ADVISED** to connect Lo or I- externally to Ground (preferably at their common junction), when the 4200 is to be used on the 100V or 1000V Range. This eliminates the risk of Lo and I- floating to high voltage.

Setting Priorities

Because of:

- a. the variety of environmental conditions and loads likely to be encountered when using the 4200,
 - b. the extensive set of combinations of outputs from the instrument, and
 - c. the accuracy required;
- it is unrealistic to describe a definitive "best" general method of connection to the load.

Combinations of the above factors can lead to conflicting requirements, and users may be faced with a choice between methods. In these cases it is sometimes necessary to arrive at a compromise solution by setting priorities.

Suggested Load Connections for the 4200

Six suggestions for connecting the 4200 to its load are illustrated in the following pages 4-4 and 4-5. Each has found use with the combination of factors described, and together they cover the majority of predicted requirements.

TYPICAL LOAD CONNECTIONS

Voltage Outputs

CAUTION: All leads and cables must be proofed to at least 2kV.

Simple 2-wire Connection.

Use for many applications where:

- The voltage drop in the leads is insignificant.
- The E-M environment is 'quiet'.
- External common-mode voltages are insignificant.

Use for measurements in the following ranges:

- Voltage $V > 100mV$
- Frequency $F < 100kHz$

Select Local Sense and Local Guard.

Keep leads as short as possible, (not longer than 1 meter - twisted pair is preferable).

On 100V/1000V Ranges Ground the Lo line for Safety.

Note: Refer also to reactive load specifications in Section 6.

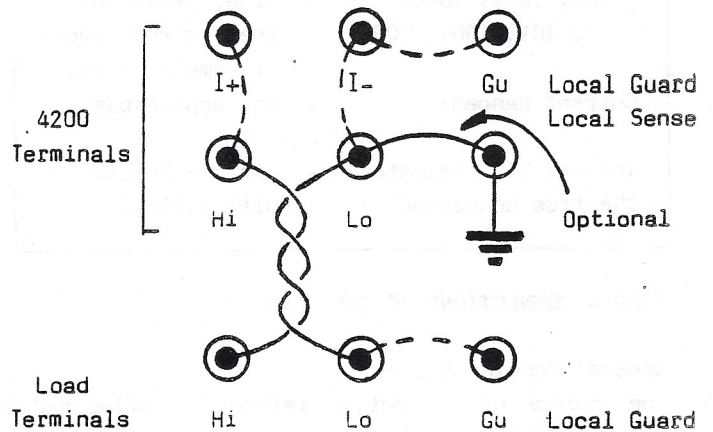

Screened 2-wire Connection.

Use where:

- Sensitive measurements are being made.
- The E-M environment is relatively 'noisy'.
- External common-mode voltages are significant.

Use for measurements in the following ranges:

- Voltage $V > 90\mu V$
- Frequency $F < 100kHz$

Select Local Sense and Local Guard.

Keep leads as short as possible, (not longer than 1 meter).

On 100V/1000V Ranges Ground the Lo line for Safety.

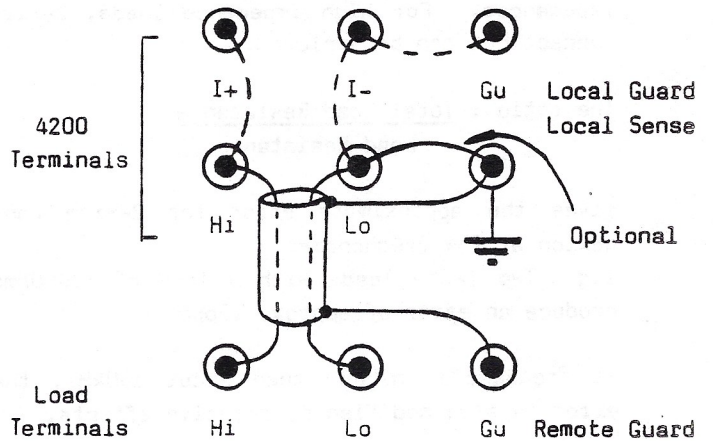

Screened 4-wire Connection using Coaxial cable.

Use where:

- The load resistance is low enough to cause a significant voltage drop in the output connection.
- Sensitive measurements are being made.
- The E-M environment is relatively noisy.
- External common-mode voltages are significant.

Use for measurements in the following ranges:

- Voltage $V > 90\mu V$
- Frequency $F < 1MHz$

Select Remote Sense and Local Guard.

Keep leads as short as possible, (not longer than 1 meter).

On 100V/1000V Ranges Ground the Lo line for Safety.

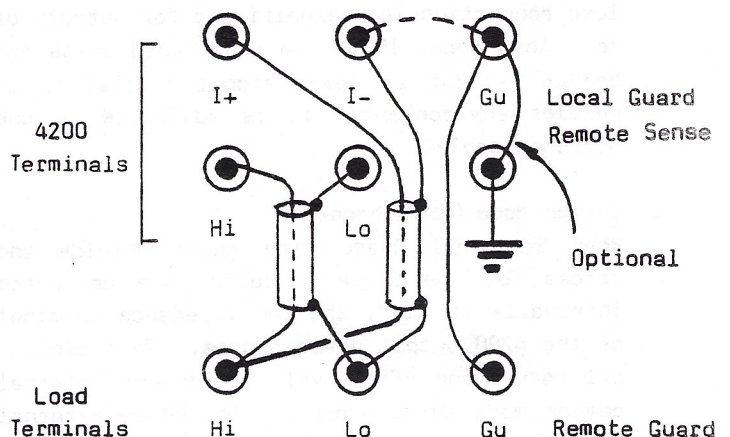

TYPICAL LOAD CONNECTIONS

Voltage Outputs (contd)

Screened 4-wire Connection.

Alternative using Twinaxial cable.

On 100V/1000V Ranges Ground the Lo line for Safety.

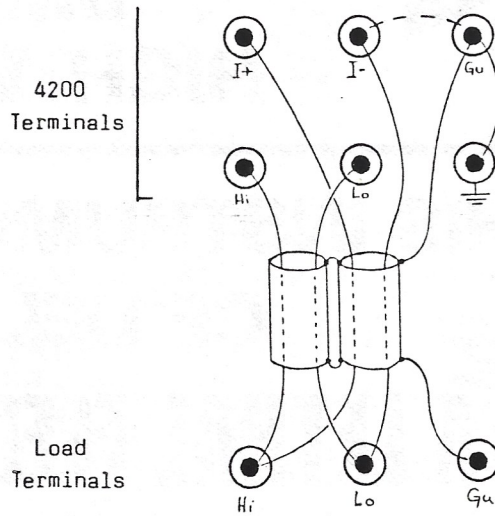

Note: Refer also to reactive load specifications in Section 6.

Current Outputs.

Simple 2-wire Connection.

Use for the majority of applications where:
The E-M environment is 'quiet'.
External common-mode is insignificant.

Use for measurements in the following ranges:

Current $I > 100\text{mA}$
Frequency $F < 5\text{kHz}$

Local Sense selected automatically.
Select Local Guard.

Keep leads as short as possible, (not longer than 1 meter - twisted pair is preferable).

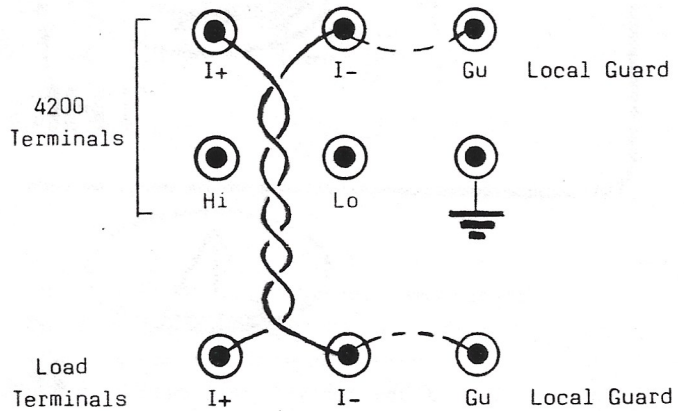

Screened 2-wire Connection.

Use where:

Sensitive measurements are being made.
The E-M environment is relatively 'noisy'.
External common-mode is significant.

Use for measurements in the following ranges:

Current $I > 9\mu\text{A}$
Frequency $F < 5\text{kHz}$

Local Sense selected automatically.
Select Local Guard.

Keep leads as short as possible, (not longer than 1 meter - Co-ax. or Twin-ax. is preferable).

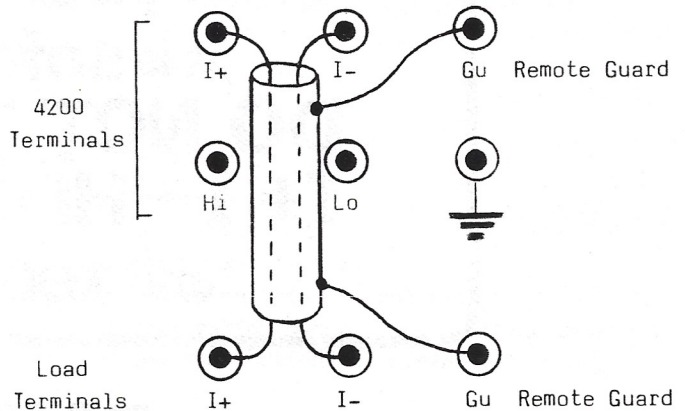

General Sequence of Operations

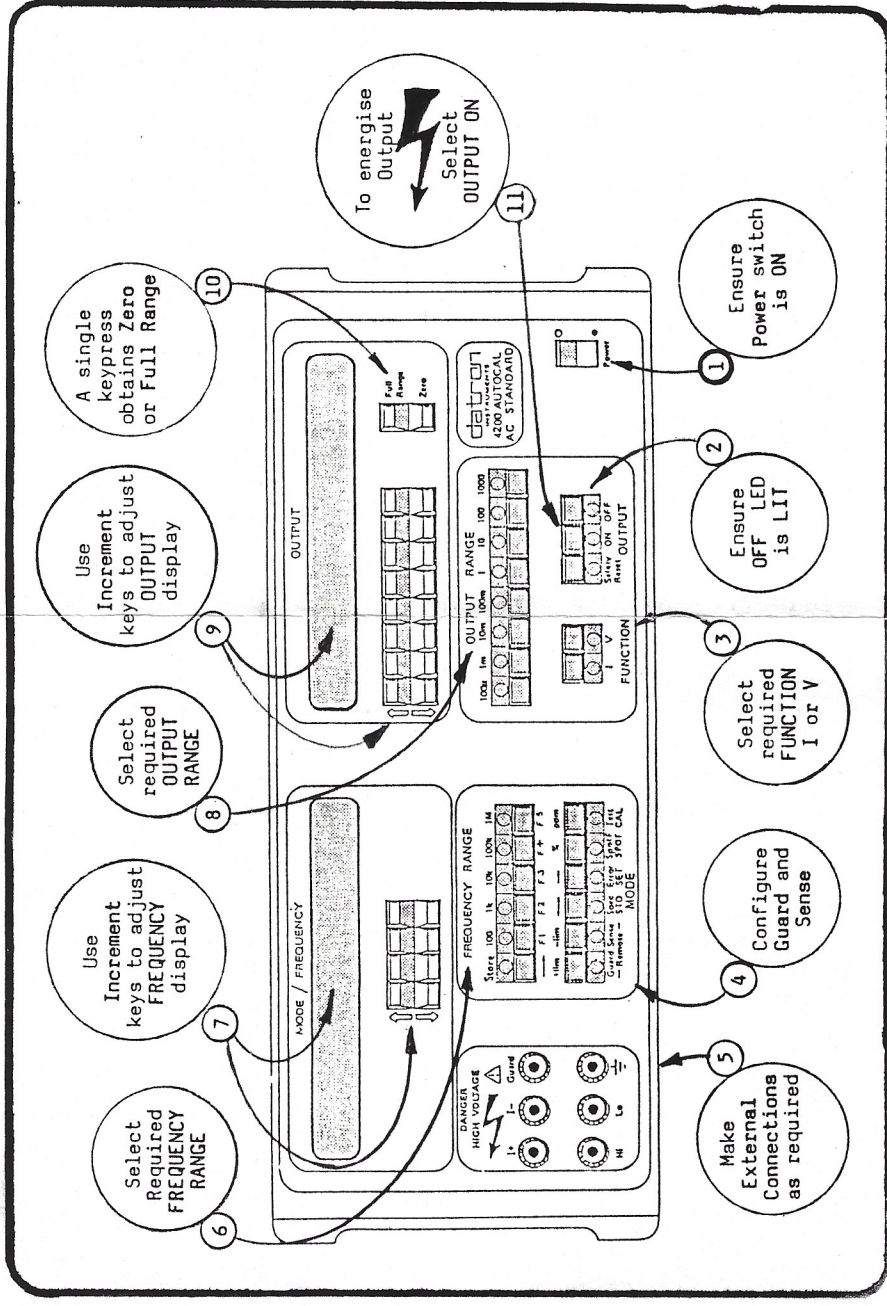

DISPLAY MESSAGES

(See full list at end of this section)

- Error 1 : Spec. mode - % : Uncertainty > 100%
- flim : Off-scale limit
- Error 2 : Cal. mode : Output not ON
- Error 3 : Cal. mode : Incorrect range or function for mode
- Error 4 : Cal. mode : Correction exceeds store capacity
- Error 5 : Error mode : Requested output would have been off-scale
- Error 7 : 100/1000V : Selected output exceeds voltage/frequency constraint
- Error 0L : Voltage : Output is current-limited
Current : Compliance limit reached

- FAIL 1 : Excessive internal temperature
- FAIL 2 : Over-voltage
- FAIL 3 : Control data corrupted
- FAIL 4 : Precision divider fault
- FAIL 5 : Safety circuits tripped
- FAIL 6 : Calibration store fault
- FAIL 7 : 400V power supply overload
Automatically resets except where hard fault occurs
- FAIL 8 : 38V power supply overload
- FAIL 9 : 15V in-guard power supply overload
- 'B' : Processor busy

Test mode messages:

- SAFETY : Forced safety trip
- RUNNING : Indicates test in progress
- PASS : Calibration memory, over-voltage detector and 400V switching checked

DANGER
HIGH VOLTAGE

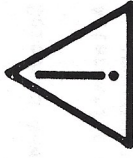

**THIS INSTRUMENT IS CAPABLE
OF DELIVERING
A LETHAL ELECTRIC SHOCK!**



FRONT or REAR
terminals carry the
Full Output Voltage.
THIS CAN KILL!

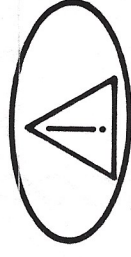

Guard terminal is
sensitive to over-
voltage

**It can damage
your instrument!**

**Unless you are sure that
it is safe to do so,
DO NOT TOUCH the
I+ I- Hi or Lo leads
and terminals**

DANGER

Operating Routines

The following operating routines are subdivided into two main types:

- Standard Operating Sequences
- Additional Facilities

Standard Operating Sequences

There are many common elements in the selection routines for both Voltage and Current operation. The diagram opposite shows the general sequence of operations. It should be used as the basis of any operating procedure, in conjunction with the individual selections detailed in the following pages.

AC VOLTAGE OUTPUTS

Zero Output

Zero Voltage output from the 4200 can be obtained only by pressing the Zero key. Internal relay contacts short I+ to I-, and Hi to Lo.

Increment from Zero

The smallest output available on any range is 9% of full range, so any attempt to reduce the output below 9% is refused. Thus the smallest possible increment from Zero is to 10% of full range, using the appropriate key (any key to the right of this would attempt to increment to 1% or less, and be refused). Half-size zeros on the Zero display show which keys cannot be used to increment from Zero; full-size zeros show those which can.

When the display is correctly incremented with OUTPUT ON, the output terminals are internally reconnected to the voltage output circuitry.

Zero Displays

Range	Zero Display
1mV	. 0 0 0 , 0
10mV	0 . 0 0 0 , 0
100mV	0 0 . 0 0 0 , 0
1V	. 0 0 0 , 0 0 0
10V	0 . 0 0 0 , 0 0
100V	0 0 . 0 0 0 , 0
1000V	0 0 0 . 0 0 0

Output Voltage Selection

There are two overlapping voltage states. The 15V overlap allows some adjustment without changing state.

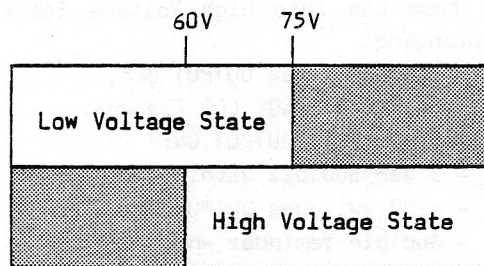

In the Low Voltage state, the output can be switched ON directly, but deliberate user-actions are required to transfer from Low to High Voltage state.

N.B. The 4200 switches its output voltage OFF each time the 1000V RANGE is selected.

Low Voltage selections (up to 75V).

Using the general sequence:

- At operation (3): Select V
- At operations (4) and (5): No Remote Sense on 1m, 10m and 100m ranges

High Voltage selections (above 75V).

Using the general sequence:

- At operation (3): Select V
- At operation (9): OUTPUT RANGE LED flashes for selections above 75V.
- At operation (12): Audible warning - 5 pulses/sec for 3 secs.
- After 3 sec. warning : 4200 switches OUTPUT ON.

While OUTPUT is ON : Audible reminder pulses continue at approx. 1 sec. intervals, and RANGE LED continues flashing.

If OUTPUT OFF or ON switching is attempted during the 3 sec. delay the 4200 reverts to OUTPUT OFF.

OUTPUT ON Transfers

If OUTPUT is already switched ON in Low Voltage State when an attempt is made to select a voltage in excess of 75V, the 4200 safety interlocks prevent the selection. Certain deliberate actions, detailed below, are then required by the operator to effect the selection.

Transfer from Low into High Voltage State, by manual upranging:

- 4200 switches OUTPUT OFF,
- Selected RANGE LED flashes.

Operator reselects OUTPUT ON:

- 3 sec audible warning
- 4200 switches OUTPUT ON
- Audible reminder while OUTPUT is ON
- RANGE LED continues flashing.
- OUTPUT ON LED lit continuously.

Transfer from Low into High Voltage State, by incrementing the OUTPUT display:

- OUTPUT remains ON at previous voltage
- OUTPUT display shows selected value
- RANGE and OUTPUT ON LEDs flash.

Operator reselects OUTPUT ON:

- 3 sec audible warning
- 4200 increases output voltage to the OUTPUT display value
- Audible reminder while OUTPUT is ON
- RANGE LED flashing
- OUTPUT ON LED lit continuously

Transfer from High into Low Voltage State, by pressing OUTPUT OFF key:

- ON LED remains lit until the output voltage has decayed (Approx. 1 sec from 1kV).

Transfer from High into Low Voltage State, by decrementing the OUTPUT display, or by manual downranging:

- Transfer to Low Voltage State is automatic when the Output Voltage falls below 60V.
- RANGE LED stops flashing - stays lit
- OUTPUT ON LED stays lit
- Audible reminder is silent

Changing Voltage State when in Error Mode

For safety reasons, the thresholds are always defined with respect to the voltage at the output terminals. When the instrument is in Error mode, the displayed output voltage is modified by the gain error, so the threshold indications may not coincide exactly with 75V and 60V on the OUTPUT display.

AC CURRENT OUTPUT (Option 30)

Zero Output

Zero Current output from the 4200 can be obtained by pressing the Zero key. This causes the internal software to isolate the I+ and I- terminals from the internal circuitry, physically interrupting the Output Current.

Increment from Zero

The smallest output available on any range is 9% of full range, so any attempt to reduce the output below 9% is refused. Thus the smallest possible increment from Zero is to 10% of full range, using the appropriate key (any key to the right of this would attempt to increment to 1% or less, and be refused). Half-size zeros on the Zero display show which keys cannot be used to increment from Zero; full-size zeros show those which can.

When the display is correctly incremented with OUTPUT ON, the I+ and I- terminals are internally reconnected to the Current output circuits.

Zero Displays

Range	Zero Display
100uA	0 0 . 0 0 0 , 0
1mA	. 0 0 0 , 0 0 0
10mA	0 . 0 0 0 , 0 0
100mA	0 0 . 0 0 0 , 0
1A	. 0 0 0 , 0 0 0

Current Outputs.

To generate output currents, use the General Sequence:

At operation (3): select I

At operations (4) and (5): No Remote Sense.

N.B. Maximum compliance 3V on all ranges.

Changing functions switches OUTPUT OFF.

Additional Facilities

CHANGE OF OUTPUT DISPLAY RESOLUTION

If high resolution is not required, the unnecessary digits can be removed from the display by the procedure shown in the example. Up to three of the least significant digits can be suppressed, leaving a minimum resolution of $3\frac{1}{2}$ digits.

Truncating the Display

The example shows blanking of the last two digits when FUNCTION V is selected. The same method is employed for FUNCTION I.

Restoring Full Resolution

The procedure can be repeated to set any required resolution in the available range; so to restore full resolution, press the least significant digit key while holding the Zero key.

Exceptions: Error Mode and Remote Operation

Any suppressed digits are restored by transfer to Remote Operation on the IEEE-488 interface, or by selection of Error mode. Full resolution persists when these facilities are deselected.

Normal Truncation in Test Mode

Selection of Test mode does not restore full resolution; and when Test mode is terminated or aborted, any previously-truncated OUTPUT display will reappear.

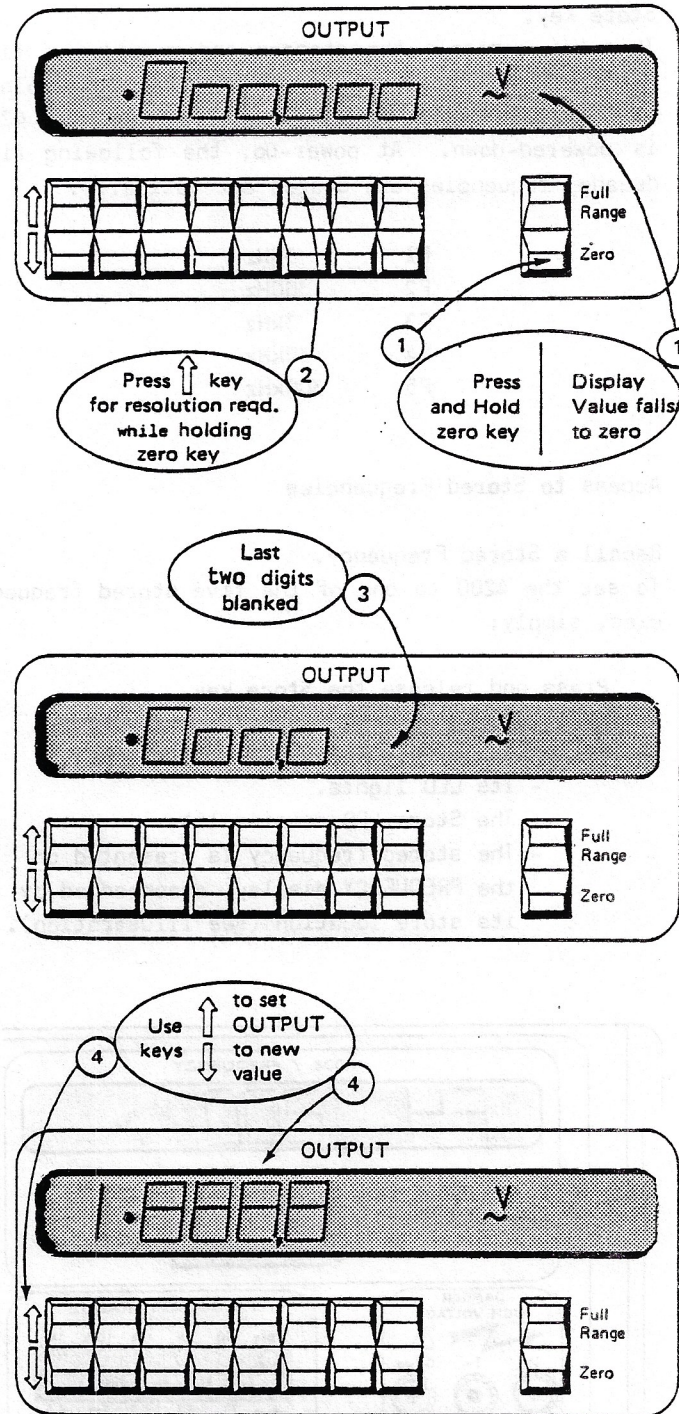

FREQUENCY STORE

Store Key.

This key controls the storage and recall of five user-selected frequencies. The memories are volatile in that their contents are lost when the 4200 is powered-down. At power-up, the following five decade frequencies are stored automatically.

F1	30Hz
F2	300Hz
F3	3kHz
F4	30kHz
F5	300kHz

Access to Stored Frequencies

Recall a Stored Frequency.

To set the 4200 to one of the five stored frequencies, simply:

Press and release the Store key.

- Its green LED lights.

Press and release the desired F1-F5 key.

- Its LED lights.
- The Store LED remains lit.
- The stored frequency is presented on the FREQUENCY display, accompanied by its store location (see illustration).

Recall from a Different Memory

To switch to a different stored frequency:

Press and release the desired F1-F5 key.

- The displayed indications change as appropriate.

Deselect Store

To revert to normal frequency facility:

Press the Store key again.

- Its LED goes out.
- The F1-F5 LED goes out.
- Frequency defaults to 1kHz (the 1kHz FREQUENCY RANGE LED lights).
- The stored frequency remains unchanged.

Re-program a Frequency Memory Store

To Change the Frequency of a Memory Store, the following procedure stores any displayable frequency in any of the five locations:

Select the required FREQUENCY RANGE.

Use the FREQUENCY display \uparrow/\downarrow keys to set the new frequency on display.

Press and hold the Store key.

- Its green LED lights.

Press and release the desired F1-F5 key.

- Its LED lights.
- The store location is also presented on the display.

Release the Store key.

- Its LED remains lit.

If desired, deselect Store as above.

Store Key - Summary

Press and Release: Accesses F1-F5 stored-frequency retrieval.

Press and Hold: Allows displayed frequency to be stored in F1-F5 memories.

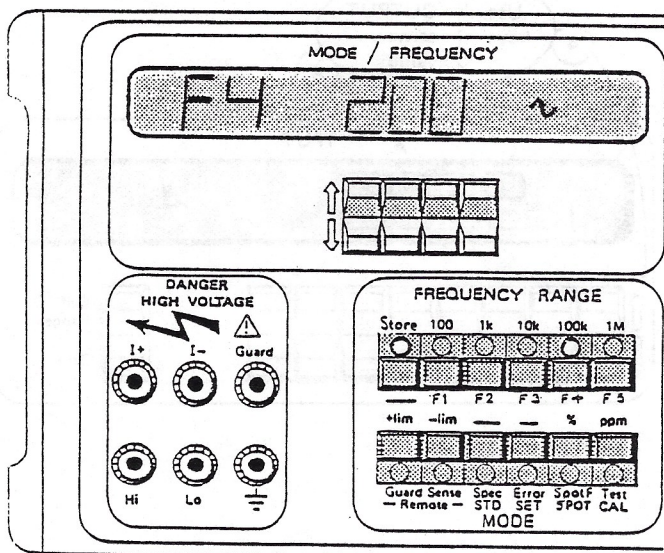

SPOT FREQUENCY

This facility exists to provide rapid access to five user-selected spot frequencies on each output Voltage and Current range. As there are seven Voltage ranges, and five Current ranges, this makes a total of sixty spots in all.

Selecting a new OUTPUT RANGE also calls up its five spot frequencies, ready for selection.

The 4200 output can be calibrated at each spot frequency, thus achieving ultra-high accuracy by eliminating the 'Flatness' component.

By using non-volatile memory, these frequencies and their associated calibration constants are retained in store, even when the 4200 is powered-down.

In order to change the frequency setting of a spot and recalibrate at the new frequency, it is necessary to enter 'cal' mode (with the rear panel CALIBRATION keyswitch set to "ENABLE").

The output level span available for calibration of Spot frequencies is restricted to within 10% of nominal full range.

The calibration procedure is described, together with the other routine calibrations, in Section 8.

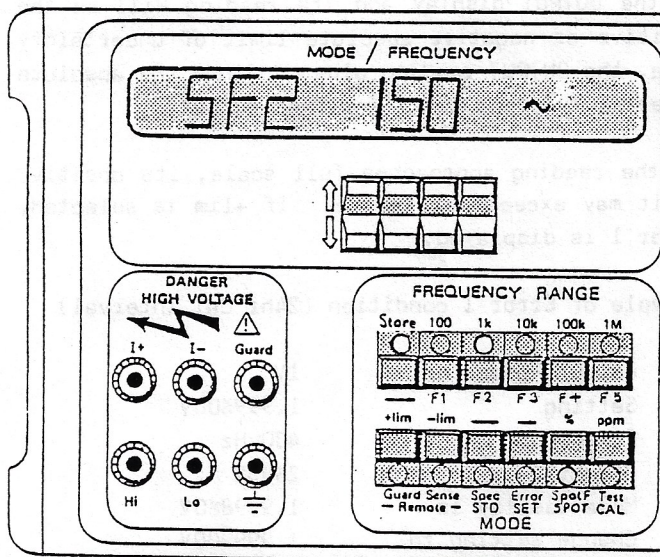

Spot F key.

This reassigns the use of the F1-F5 keys, to provide read-access to the non-volatile memory.

Recall.

To set the 4200 to one of the existing spot frequencies, with output as previously calibrated, simply:

Press and release the Spot F key.

- Its LED lights.
- The Store LED lights.

Press and release the desired F1-F5 key.

- Its LED lights.
- The Store and Spot F LEDs remain lit.
- The spot frequency is presented on the FREQUENCY display, accompanied by its store location (see illustration).

Recall from a Different Memory.

To switch to a different spot frequency.

Press and release the desired F1-F5 key.

- The displayed indications change as appropriate.

If the spot has not previously been calibrated, the message "SFX----" is displayed (X is the store number). The most recent frequency setting is retained.

Output and Frequency Constraints.

If the combination of voltage and frequency, or current and frequency, is outside the defined constraints, the command to change spot, output range or output value will be ignored.

Deselect Spot Frequency.

To revert to normal frequency facility:

Press either Spot F or Store.

- Spot F LED goes out.
- Store LED goes out.
- The selected F1-F5 LED goes out.
- 1k FREQUENCY RANGE LED lights.
- FREQUENCY display reverts to 1kHz.
- 4200 frequency reverts to 1kHz.
- The stored spot frequency remains unchanged.

Re-program a Frequency Memory Store

To change the frequency of a memory store, the 4200 must be placed into "cal" mode. This procedure is detailed in Section 8.

SPECIFICATION MODE

Spec Key.

This key allows a user to avoid constantly referring to the data sheet specifications, when it is necessary to determine the uncertainty for any set value.

Uncertainty Data Selection.

The range of 4200 specification uncertainties is held in internal memory. Spec mode selects the stored data appropriate to the current settings of Function, Range, Output Value, Frequency and Calibration Interval; then calculates and displays the overall uncertainty.

Initiation.

To transfer into Spec mode:

Select the required Calibration Interval (Rear Panel switch).

Then follow the sequence in the diagram:

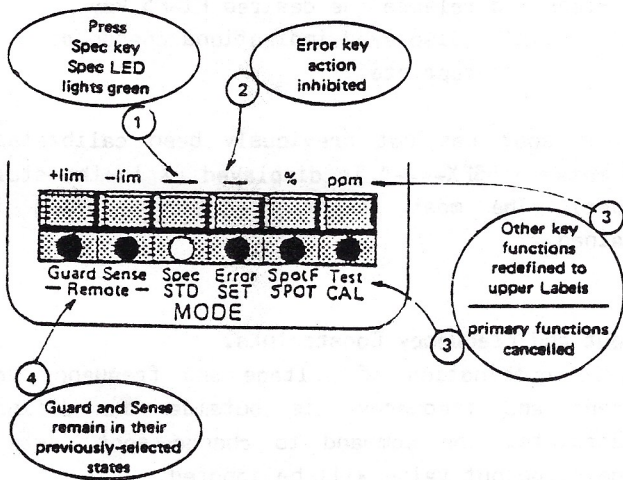

On pressing the Spec key the uncertainty appears on the MODE display, displacing the Frequency readout (Except for Spot F and Store, Frequency cannot be changed when in 'Spec' mode). Initially the presentation is as shown in the following table:

Uncertainty	Display Units
< 1,999ppm of set value	. ppm
> 1,999ppm of set value	%
Not displayable or > 100%	Error 1

Secondary Spec Modes.

Once the Spec key has been pressed, the other MODE keys become reassigned to give a choice of four display modes:

ppm, %, +lim, -lim.

ppm or % Uncertainty (of displayed value).

From 1ppm to 1999ppm, the uncertainty can be displayed in ppm. From 0.001% to 100%, it can be displayed in %. When the uncertainty is not defined, the message Error 1 is displayed.

Example of Error 1 Condition (Any Cal Interval set)

Output Range Setting	1V
Frequency	Zero key pressed
Uncertainty	Any frequency.
Mode display is	Not defined at Zero.
	Error 1.

NB. The Zero Voltage output from the 4200 is a hard-wired short-circuit.

+Lim or -Lim.

To obtain a reading of an absolute limit of uncertainty:

Press the +Lim or -Lim key.

The MODE display will switch to the same resolution as the OUTPUT display and its reading will be the positive or negative absolute limit of uncertainty (i.e. the OUTPUT reading plus or minus the absolute uncertainty error limit for that output).

As the reading approaches full scale, its positive limit may exceed full scale. If +lim is selected, Error 1 is displayed.

Example of Error 1 condition (24hr Cal Interval)

Output Range Setting	1V
Frequency	1.999600V
Uncertainty	400kHz
Mode display is	260uV
Change setting to	1.999860V
Mode display is	1.999900V
	Error 1 (uncertainty not displayable).

FUNCTION and RANGE Control in Spec Mode

The FUNCTION, OUTPUT RANGE and OUTPUT \uparrow/\downarrow keys can be operated normally. The 4200 will adjust its MODE display to the uncertainty figure appropriate to each new selection.

FREQUENCY Selection in Spec Mode

The MODE/FREQUENCY display is assigned to its "Uncertainty" presentation, and the Spot F key is assigned to % . Consequently the use of the FREQUENCY RANGE, FREQUENCY \uparrow/\downarrow , Store and Spot F keys is inhibited.

Nevertheless, by pressing the Spot F key followed by one F1-F5 key BEFORE pressing Spec, all sixty "spot" frequencies can still be accessed, the output being modified by the previously calibrated correction as normal. A similar procedure using the Store key will access the five "stored" frequencies.

In both of these cases the MODE display normally presents the appropriate uncertainty figure. But a readout of the Spot or Stored frequency can be obtained by merely pressing and releasing the F1-F5 key whose LED is lit. The store location and frequency will appear for about 1 second, before changing back to the uncertainty figure.

If an uncalibrated Spot frequency is selected, the normal indication is given.
ie: "SFX----", where X is the store location.

A typical sequence using the "Store" facility at 10V on the 10V range is illustrated below (power-up frequencies used):

Operation	MODE/FREQUENCY Display
Store - F2	F2 300
Spec	\pm 50 ppm
F4	\pm 55 ppm
F4 again	F4 30 k
After 1 sec	\pm 55ppm

4200 'Spec' Data

Section 6 breaks down the specification into:

- Stability,
- Accuracy relative to Standards ($23^{\circ}\text{C} \pm 5^{\circ}\text{C}$),
- Datron's Calibration Uncertainty.

The CALIBRATION INTERVAL switch on the rear panel of both models is labelled:

24hr, 90dy, and lyr.

The stored uncertainty data is selected from (a), (b) and (c) above, as follows:

- 24hr: (a) Stability
90dy: (b) + (c) 5°C Accuracy plus Uncertainty
lyr: (b) + (c) 5°C Accuracy plus Uncertainty

Thus the accuracy figures displayed for 90dy and lyr are traceable to National Standards.

In verifying the instrument's specification on receipt of a 4200, users are able to display the 90-day limits to check against the instrument's specified traceable accuracy. After recalibration, the "24 hour interval" limits should be used to verify against the same standards used for calibration under the same environmental conditions.

Refer to Section 7, Specification Verification, for further information.

'ERROR' MODE

The specification of a high accuracy AC DMM (and of other AC measuring equipment) relates its display readings to its input values. A perfectly calibrated DMM would have an exact 1:1 correspondence, and the specification lays down acceptable tolerances of deviation from this direct relationship. Plotted as a graph, the ideal case is a straight line at 45° through the origin. The tolerances plotted on the graph enclose an area on both sides of this line:

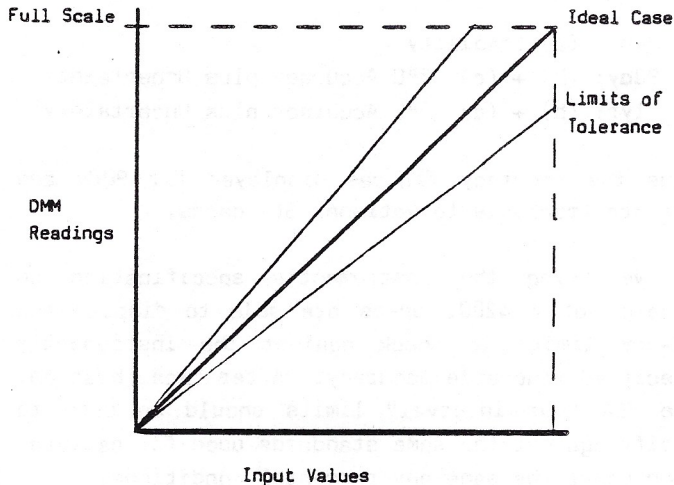

There are two major causes of deviation from the ideal case:

- Gain Error - the overall slope of the line is not 45°
- Linearity and Offset Error - the slope is not constant.

Either of these elements, or a combination, could cause large enough deviations to place the instrument out of tolerance. Without an easy method of discounting the gain error, a complicated analysis is necessary to determine which errors are responsible.

"Error" mode simplifies this analysis. It allows a user to identify the cause of excessive deviation, by compensating for gain errors.

Error Key

The Error key is used to initiate Error mode. The 4200 terminal value can then be deviated from the OUTPUT display value, by known gain factors, as entered on the MODE display.

Error Mode Display

Pressing the Error key changes the MODE/FREQUENCY display from "Frequency" readout to "Error Mode" readout. The initial reading is always "0.0 ppm", indicating that the terminal value has not yet been deviated.

MODE/FREQUENCY ↑/↓ Keys

The terminal value is changed, without altering the OUTPUT display, by pressing the ↑/↓ keys beneath the MODE/FREQUENCY display. The gain compensation being applied is displayed as a percentage or ppm of the OUTPUT display value; with positive polarity for an increase of terminal value, and negative for a decrease.

The gain-compensation factor has a maximum possible resolution of ± 1 ppm of Full Range. The extreme right-hand digit of the readout (0.1 ppm) is not significant.

OUTPUT Display Truncation

The OUTPUT display cannot be truncated in Error Mode. Any previous truncation (see page 4-9) is cancelled, and full resolution persists when Error Mode is deselected.

Example of the Use of "Error" Mode

To measure the linearity of an AC DMM, a user needs to compensate each input for the DMM's gain error before linearity errors can be calculated.

Using Error Mode, once the gain error has been found at, say, Full Range; the 4200 automatically calculates and applies gain compensation to all its outputs on that Range and Function. Meanwhile, it displays both the nominal (uncompensated) value of output and the gain compensation. Only if the DMM response is linear, will each DMM reading agree with the corresponding 4200 OUTPUT display value.

In the following sequence diagram, a DMM is checked for linearity. For purposes of explanation, it is assumed that linearity is correct, but the DMM has a gain error of +100ppm.

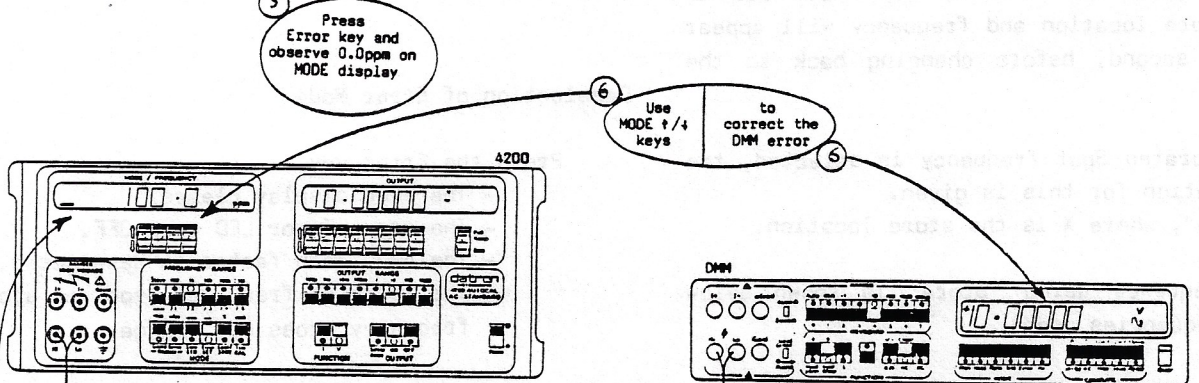
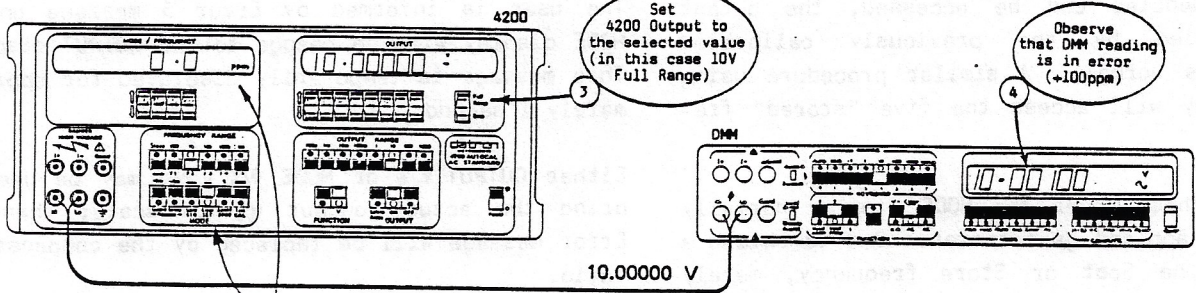
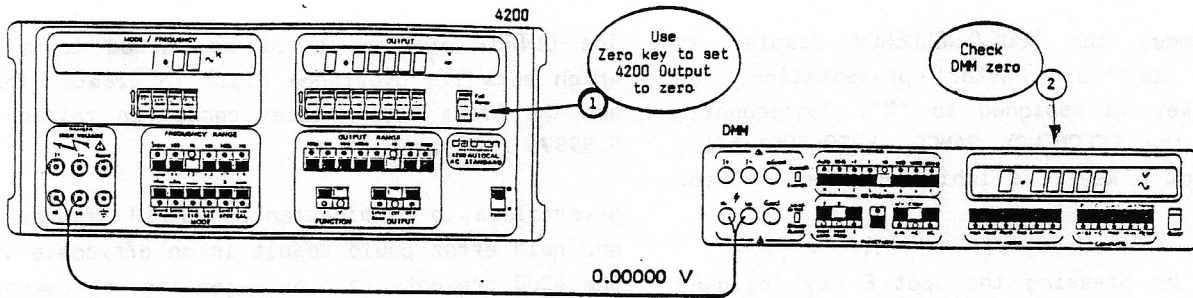

7 MODE display presents compensation ratio

$$9.99900 \text{ V} = 10\text{V} + (-100 \text{ ppm} \times 10\text{V})$$

$$\text{compensated value} = \text{set value} + (\text{Compensation ratio} \times \text{set value})$$

The 4200 output has now been compensated for the gain error of the DMM. All selected output values will be compensated in the same ratio on this Range and Function until either the ratio is changed or Error mode is deselected. The Mode display presents the compensation ratio directly.

Note that the compensation sense is shown, not the error sense, therefore the true output is the sum of both displayed values - in this case:

$$10.00000\text{V} - 100\text{ppm} = 9.99900\text{V}.$$

The linearity of the DMM may now be checked by directly comparing its readings with the OUTPUT display settings.

e.g. at 5V on this range, both 4200 and DMM read 5.00000V, although the terminal voltages are 4.99950V

Other linearity check values could be:

Nominal Check Point	4200 set Value	DMM Reading	Terminal Voltages
1V	1.00000V	1.00000V	0.99990V
19V	19.00000V	19.00000V	18.99810V

Error Mode Frequencies

In Error mode, the MODE/FREQUENCY display is assigned to its 'Gain Factor' presentation, and the Spot F key is assigned to '%'. Consequently the use of the FREQUENCY RANGE, FREQUENCY \uparrow/\downarrow , Store and Spot F keys, is inhibited when in Error mode.

Nevertheless, by pressing the Spot F key followed by one F1-F5 key BEFORE pressing Error, all sixty "spot" frequencies can be accessed, the output being modified by the previously calibrated correction as normal. A similar procedure using the Store key will access the five "stored" frequencies.

In both of these cases the MODE display normally presents the applied gain factor. But to obtain a readout of the Spot or Store frequency, merely press and release the F1 - F5 key whose LED is lit. The store location and frequency will appear for about 1 second, before changing back to the gain factor.

If an uncalibrated Spot frequency is selected, the normal indication for this is given.
ie: "SFX----", where X is the store location.

A typical sequence using 'Store' is shown below (power-up frequencies used)

Operation	MODE/FREQUENCY Display
Store - F2	F2 300
Error	0 ppm
MODE \uparrow/\downarrow	+ 10 ppm
F2 again	F2 300
After 1 second	+ 10ppm
F4	+ 10ppm
F4 again	F4 30 k
After 1 sec.	+ 10 ppm

Full Scale Limiting.

The OUTPUT display cannot be raised to a value which sets its overrange digit to greater than 1, and the Error Mode display cannot be raised above 9.9999% (999 ppm).

Nevertheless, a combination of OUTPUT display value and gain error could result in an off-scale value. The 4200 prevents this by rejecting any demand for an error-corrected value in excess of full scale. The user is informed by Error 5 message on the MODE display with no change to the OUTPUT display. This message is temporarily displayed for approximately 1 second.

Either OUTPUT \uparrow/\downarrow or MODE \uparrow/\downarrow keys may be used to bring the actual output within scale; then the Error message will be replaced by the compensation ratio.

Deselection of Error Mode

Press the Error key.

- The MODE display clears.
- The green Error LED goes OFF.
- The 4200 gain factor is deselected.
- The selected frequency, spot or stored frequency, does not change.

Although the mode is normally deselected by repressing the Error key, it is also turned off by changing FUNCTION or RANGE.

After leaving Error mode, the OUTPUT display resolution remains at maximum for the Function and Range selected.

Test Key

Tests available.

There are two stages of 'Test' mode. The first stage, Safety and Memory checks, cannot be omitted from any 'Test' sequence.

Safety and Memory checks

On first pressing the Test key, the 4200 carries out three checks:

1. Operation of the Safety trip, buzzer and reset circuitry.
2. Calibration Memory integrity.
3. Over-voltage check. (High voltage when not in HV state).

Messages appear on the MODE display, and completion is signalled by the Test LED going OFF. The second stage Display and Key checks may be omitted by pressing any key other than Test.

Display and Key checks

If the Test Key is re-pressed before pressing any other key, a visual sequence tests the front panel:

1. Gas discharge displays
2. Key LEDs
3. Key contacts (user-selected)

The 4200 remains in the key-contact mode until the Zero Key is pressed or test is deselected. It may then be used normally.

NOTE: At any time during the second stage, the Test sequence may be aborted by pressing Test Key again.

Test Sequence

The Front or Rear panel terminals are not energised during Test sequence.

Safety and Memory checks.

1. Initial Conditions.

Ensure that OUTPUT OFF LED is lit, Error and Spec LEDs are unlit. Check that Test LED is unlit. Selftest is only accepted if some output other than zero has been selected.

2. Press Test Key:

Test LED lights as the checks begin.

3. Safety Trip Check.

The 4200 tests the safety trip circuits. The SAFETY message appears on the MODE display and the buzzer will sound continuously when the trips have operated, and the Safety Reset LED flashes.

4. Safety Reset Check

The program ensures that a user tests the Safety Reset action.

Press Safety Reset Key:

The SAFETY message is replaced by the running message and the buzzer stops sounding. Relay operation can be heard during the automatic checks which follow.

5. Calibration Memory Check.

This is a sum-check of the Non-Volatile RAM. If the check fails, the Message FAIL 6 appears, otherwise no message.

6. Over-Voltage Checks.

The 4200 automatically tests the over-voltage detector threshold levels in Low Voltage state.

If the check fails, the message FAIL 2 appears, otherwise PASS message indicates both tests completed successfully.

7. The Test LED goes OFF

The following table summarizes the MODE display messages:

Message	Reason
SAFETY running	First stage of 'test' operative.
PASS	No failure discovered.
FAIL 6 only	Parity error in Calibration Memory check.
FAIL 2 only	High voltage can be present in Low Voltage state.

Any combination of these three FAIL messages can appear in sequence, replacing the running message.

8. To terminate Test before the Display and Key checks, press any key other than Test:

4200 reverts to initial conditions

Operate 4200 normally.

Display and Key Checks.

Visual Check Sequence - read this Note before pressing Test Key to start.

NOTE: After pressing Test Key, the Visual Check Sequence commences. During this sequence observe that:

- (a) No display segments or blocks are missing or incomplete.
- (b) Segments and blocks do not appear spuriously.
- (c) Inter-digit and inter-segment 'streaming' does not occur.
- (d) All LED's are lit in their correct sequence.
- (e) LEDs are not lit spuriously.

1. Press Test key - Test LED lights
 - All other LEDs unlit
 - Displays cleared momentarily,
 then:

2. MODE Display

- (a) Initial presentation:

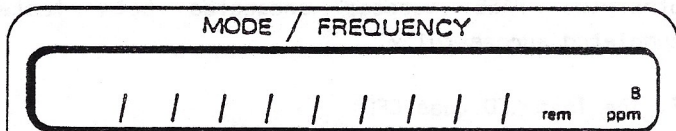

nine segments and legends are presented.

- (b) Progressively, all seven-segment digits and legends are displayed segment by segment.

N.B. Commas are not presented in the MODE display sequence.

- (c) MODE display cleared.

3. OUTPUT Display

- (a) Initial presentation:

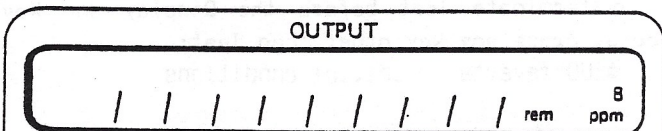

nine segments and legends are presented

- (b) Progressively, all seven-segment digits and legends are displayed segment by segment.
- (c) Final presentation: Nine commas are displayed on OUTPUT display then all 18 commas are displayed on OUTPUT and MODE displays.
- (d) OUTPUT and MODE displays cleared.

4. MODE display

- (a) Initial presentation:

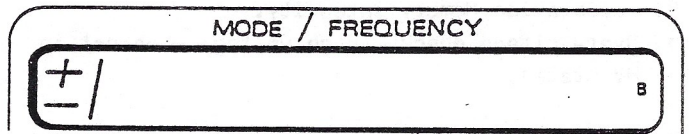

Polarity signs and overrange digit displayed.

- (b) Progressively, seven-segment digits are presented digit by digit
- (c) Final presentation.

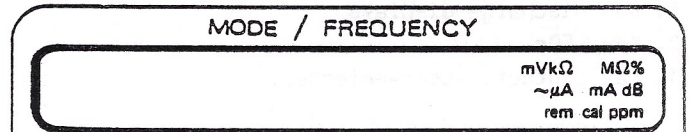

First, then second blocks of legends are displayed

- (d) MODE display cleared.

5. OUTPUT display digits are presented next, in the same order as for the MODE display.

6. LED Check sequence commences:

- (a) Test LED stays on, and other key LEDs are lit in Left to Right sequence starting at 100 key and ending at OFF

- (b) MODE display

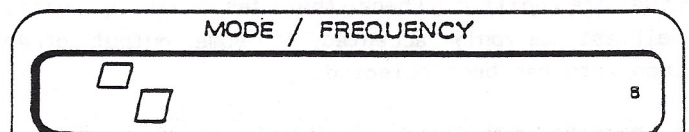

Symbol shown indicates that the keys are ready to be checked.

7. Key Checks

N.B. The Zero key should not be pressed until it is desired to terminate the Test Sequence.

(a) Keys

Each \uparrow key should light the upper half of the digit immediately above it.

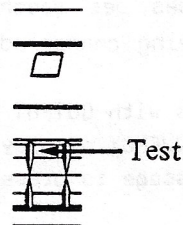

OUTPUT Display overrange digit \uparrow key.

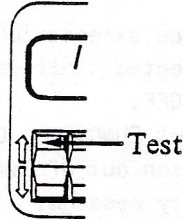

Each \downarrow key should light the lower half of the digit immediately above it.

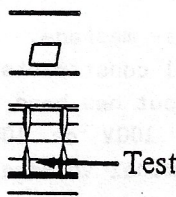

OUTPUT Display overrange digit \downarrow key.

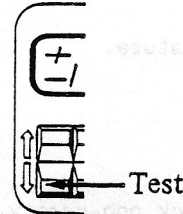

(b) FREQUENCY RANGE, MODE, OUTPUT RANGE, FUNCTION, and OUTPUT keys should cause their LEDs to light, except:

- (i) Safety Reset key, which is inoperative,
- and (ii) Test key, which aborts the test.

In these tests the key-press operates a latch so that the display or LED remains lit until another key is pressed. Only one key-press at a time is recognised.

(c) To Terminate the Test Sequence:

- Press Zero key to check its operation.
- 4200 reverts to initial conditions.
- Test LED goes OFF

(d) Operate 4200 normally

Messages and Warnings

Audible Warning

- (a) Sounds at rate of approx 5 pulses per second during the 3 second delay between selection of OUTPUT ON and the High Voltage being connected to the terminals, when the OUTPUT TERMINAL VOLTAGE WILL EXCEED 75V.
- (b) Sounds at approx 1 second intervals with OUTPUT ON in High Voltage State.
- (c) Sounds for 1 second with blank FREQUENCY display when frequency auto-ranges up or down.
- (d) Sounds continuously when SAFETY message is present on MODE display during self test.

FREQUENCY / MODE display

- Error 1 - Spec Mode : [%] - Tolerance exceeds 100%.
 : [+Lim, -Lim] - The selected limit is off-scale.
- Error 2 - Calibrate Mode - OUTPUT OFF.
- Error 3 - Calibrate Mode - Incorrect FUNCTION, OUTPUT or FREQUENCY RANGE for this calibration mode.
- Error 4 - Calibrate Mode - Correction out of limits.
- Error 5 - Error Mode - Temporary message. The selected deviation would cause the output to exceed full-scale value. Activation has been prevented.
- Error 6 - Not used in the 4200.
- Error 7 - 100V and)
 1000V Ranges } - Temporary message. The selected Voltage and Frequency exceeds the 4200 internal constraints. Activation has been prevented.
- Error OL- Voltage Ranges - The output has been current-limited by an overload.
 (If in 100V or 1000V range, OUTPUT is automatically switched OFF).
- Current Ranges - The terminal voltage has been compliance-limited to 3V.
 (Load impedance too high)

- FAIL 1 - Excessive internal temperature.
- FAIL 2 - Over-voltage.
- FAIL 3 - Control data corrupted.
- FAIL 4 - Precision divider fault.
- FAIL 5 - Safety circuits tripped.
- FAIL 6 - Calibration memory sumcheck non-parity.
- FAIL 7 - 400V power supply fault - this 'trip' may reset itself if no hardware fault exists and the Fail message be temporary.
- FAIL 8 - 38V power supply fault.
- FAIL 9 - 15V in-guard power supply fault.

SAFETY - Test Mode - Safety circuits tested by tripping: Press Safety Reset key to continue test.

running - Test Mode - Indicates test in progress.

PASS - Test Mode - FAIL 6 did not occur during test of calibration memory parity,
 and FAIL 2 did not occur during test of over-voltage thresholds.

Recalled Messages

ISSUE XX - Firmware issue number (selected by pressing Error then -Lim).

Addr XX - IEEE 488 Bus Address as set on Address switch (selected by pressing Error then +Lim).

Processor "Busy"

The 4200 will not respond to commands while legend 'B' is present on the MODE and OUTPUT displays except to override during safety delay.

KEY LEDs

Basic Indications:

- Lit - The labelled facility is selected and active.
- Unlit - The labelled facility is not selected.
- Lit Green (Spec and Error only) - Other MODE keys' facilities are reassigned to the secondary modes printed ABOVE their keys, as directed by the arrows.
- Lit Green (Store only) - FREQUENCY RANGE keys are reassigned to select F1-F5 memory stores.

Warnings with Function V Selected:

- OUTPUT RANGE 100V or 1000V LED flashing
 - A voltage in excess of 75V RMS has been selected (OUTPUT ON or OFF).
- ON LED flashing while in Low Voltage State with OUTPUT ON
 - An attempt to select output in excess of 75V has been prevented.
 - Repeating OUTPUT ON key will switch the HIGH VOLTAGE ON.

SECTION 5 SYSTEMS APPLICATION VIA THE IEEE 488 INTERFACE

Introduction

Section 5 gives the information necessary to put the 4200 into operation on the IEEE 488 bus. As some operators will be first-time users of the bus, the text is pitched at an introductory level. For more detailed information, refer to the standard specification, which appears in the publication ANSI/IEEE Std.488-1978.

Section Contents

The section is divided so as to group certain types of information together. These divisions are:

Interface Capability - the permitted options which have been implemented in the 4200.

Typical System - a brief view of a typical process using the 4200 to check a DMM calibration.

Using the 4200 in a System - implications of bus operation.

Programming Instructions - how the 4200 facilities have been transferred into remote commands.

Programming of Operational Functions - more detail about the codes which control 4200 operation.

Programming of Bus Transmissions - how to program the 4200 to obtain specific types of readout.

Service Request - why the 4200 needs the controller's attention and how it gets it.

Activation of Commands - what the 4200 does with the commands it receives.

Operational Sequence Guidelines - a little general help with programming sequences.

INTERFACE CAPABILITY

IEEE Standard 488

The 4200 conforms to the Standard Specification IEEE 488-1978 - "IEEE Standard Digital Interface for Programmable Instrumentation".

It can be connected to the IEEE 488 Interface Bus and set into programmed communication with other bus-connected devices under the direction of a system controller.

Programming Options

The instrument can be programmed via the IEEE Interface, to:

- (1) Change its operational state (Range, Function, Frequency, Mode, Output etc).
- (2) Transmit its own status data to other devices on the bus.
- (3) Request service from the system controller.

Capability Codes

To conform to the standard specification, it is not essential for a compatible device to encompass the full range of bus capabilities.

The IEEE 488 document describes and codes each of the standard bus features, so that manufacturers can provide brief coded descriptions of their own interfaces' overall capability. A code string is often printed on the product itself.

The codes which apply to the 4200 are given in table 5.1, together with short descriptions. They also appear on the rear of the instrument next to the interface connector.

Appendix C of the IEEE 488 document contains a fuller description of each code.

Code	Interface Function
SH1	Source Handshake Capability
AH1	Acceptor Handshake Capability
T6	Talker (basic talker, serial poll, unaddressed to talk if addressed to listen)
TE0	No Address Extension Talker Mode
L3	Listener (basic listener, listener-only mode, unaddressed to listen if addressed to talk)
LE0	No Address Extension Listener Mode
SR1	Service Request Capability
RL2	Remote/Local Capability (without Local Lockout)
PP0	No Parallel Poll Capability
DC1	Device Clear Capability
DT0	No Device Trigger Capability
C0	No Controller Capability
E1	Open-Collector Drivers

Table 5.1 IEEE Interface Capability

Bus Addresses

When an IEEE 488 system comprises several instruments, a unique 'Address' should be assigned to each to enable the controller to communicate with them individually.

One address is sufficient for a Datron instrument, as the controller can add information to it to define either 'talk' or 'listen'.

Interconnections

Instruments fitted with an IEEE 488 interface normally communicate through a set of interconnecting cables, specified in the IEEE 488-1978 Standard document.

The 4200's interface connector, J27, is fitted on its rear panel. It receives the specified connector, whose pin designations are also standardized and shown in Fig. 5.1 and Table 5.2

Fig.5.1 J27 Pin Layout

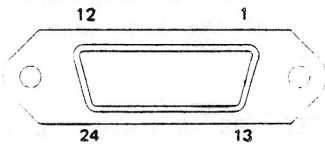

J27 Pin No	Name	Description
1	DIO 1	Data Input Output Line 1
2	DIO 2	Data Input Output Line 2
3	DIO 3	Data Input Output Line 3
4	DIO 4	Data Input Output Line 4
5	EOI	End or Identify
6	DAV	Data Valid
7	NRFD	Not ready for Data
8	NDAC	Not Data Accepted
9	IFC	Interface Clear
10	SRQ	Service Request
11	ATN	Attention
12	SHIELD	Screening on cable (connected to Safety Ground)
13	DIO 5	Data Input Output Line 5
14	DIO 6	Data Input Output Line 6
15	DIO 7	Data Input Output Line 7
16	DIO 8	Data Input Output Line 8
17	REN	Remote Enable
18	GND 6	Gnd wire of twisted pair with DAV
19	GND 7	Gnd wire of twisted pair with NRFD
20	GND 8	Gnd wire of twisted pair with NDAC
21	GND 9	Gnd wire of twisted pair with IFC
22	GND10	Gnd wire of twisted pair with SRQ
23	GND11	Gnd wire of twisted pair with ATN
24	GND	4200 Logic Ground (Internally connected to 4200 Safety Ground)

Table 5.2 IEEE 488-1978 Connector - Pin Designations

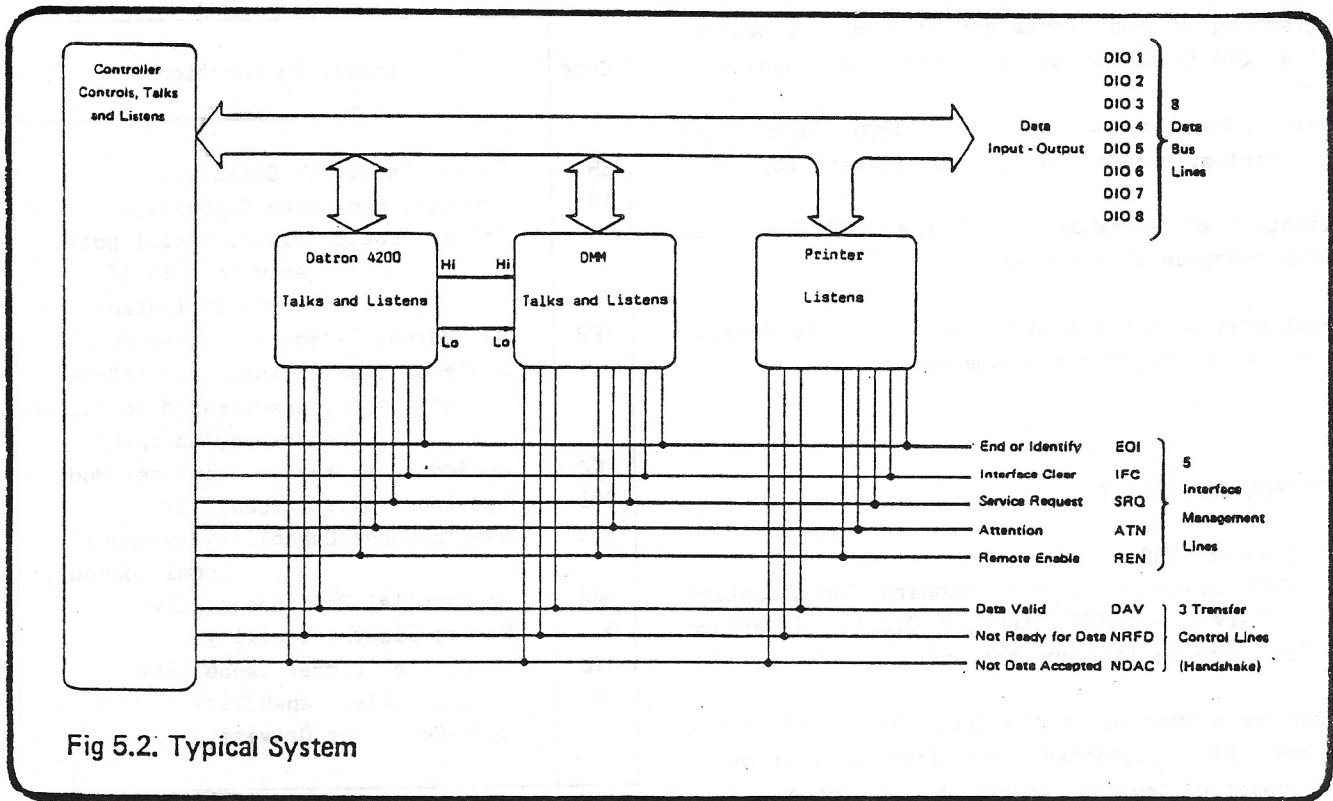

Fig 5.2. Typical System

Typical System

A typical system is shown in Fig. 5.2. The system is directed by a controlling device able to:

- (a) "Control" (Issue commands)
- (b) "Listen" (Receive data)
- and (c) "Talk" (Transmit data)

EXAMPLE OF A SYSTEM IN OPERATION

In the system example (Fig. 5.2) the programmed task could be to check the DMM calibration against the 4200, and print out the results. The following is a typical sequence of events:

- (1) The controller needs to instruct the 4200 to set its output to a calibration point for the DMM. These commands must not be received by the DMM or the printer and so the controller sends the general bus message "Unlisten". When sending general messages, the controller makes all bus devices interpret any DIO-line data as configuration or data-flow commands, by holding the ATN line true.
- (2) The controller then sends the 4200's listen address to force it to receive, followed by 4200 configuration commands (including the Output Disable message, to prevent the DMM receiving an inappropriate analog input). The instructions are passed along the DIO (data input-output) lines as coded messages (bytes). The code used is ASCII (American Std. Code for Information Interchange).
- (3) Although the 4200 accepts the instructions as they are passed, their implementation takes a short time. The controller would perform other tasks during this period. In the example, it would pass configuring commands to the DMM, after 'Unlisten' and the DMM listen address have been sent.
- (4) The DMM also needs time to settle into stable operation, so the controller performs other tasks while waiting, such as configuring the printer.
- (5) The controller next generates 'Unlisten' addresses the 4200 as listener, and re-configures its Analog Output On by an Output Enable message. If the 4200 has executed its previous instructions, it sets OUTPUT ON immediately, otherwise the OUTPUT is set ON as soon as they have been executed. In either case, the instrument sends a message back to the controller via the SRQ (Service Request) management line, if programmed to do so.
- (6) As the SRQ facility is available to all bus devices (Wired-OR function), the controller needs

to discover which one sent the 'SRQ'. It therefore asks all devices one by one ("serial poll"), finds out that the 4200 is the SRQ source and that its OUTPUT is ON.

(7) It next addresses the DMM as a listener, and sends the GET message (Group Execute Trigger) via the DIO lines to initiate the reading. After a short delay for measurement, the DMM prepares output data and SRQ's the controller when it is ready for transfer.

(8) The controller identifies the DMM by a serial poll. Finding that the reading is available, it sends the DMM's talk address, and printer's listen address, to activate both devices.

(9) The controller sets the ATN line false, thus releasing both devices to start the transfer. The DMM sends its data, byte by byte, via the DIO lines to the printer. This data must be in a form acceptable to the printer, and to ensure orderly transfer, each byte is transferred by "Handshake", using the three Transfer-Control lines.

(10) Usually the controller is also listening to this data transfer to determine when it is complete. As an aid to the controller and printer, the DMM can send another message with the last byte to be transferred (EOI-end or identify, using another bus management line).

(11) The sequence is complete, and the controller can start again at another calibration point.

The controller holds the REN line true when taking remote control. It can send an addressed command GTL, or some controllers can set REN false, to permit temporary manual control of a device. The IFC line is used at the discretion of the controller, to clear any activity off the bus.

Sequences such as this are often assembled into programs to check DMMs at many calibration points; changing functions, ranges and output levels as designed by the user. The program would also include 'display' messages to complete the printout in a recognisable form for the user's convenience. Programs must also cater for FAIL and ERROR SRQs.

With a Datron Autocal DMM, other sequences can cause the DMM errors to be reduced until they are within specification, using its 'calibrate' mode.

Using the 4200 in a System

ADDRESSING THE 4200

Bus Address

The instrument address is set manually using a six way miniature switch near the interface connector on the rear panel. Five of the switches are used to set any address in the range 00 to 30, using a binary code.

e.g. Switch setting – ADD 11010 = ADDRESS 26

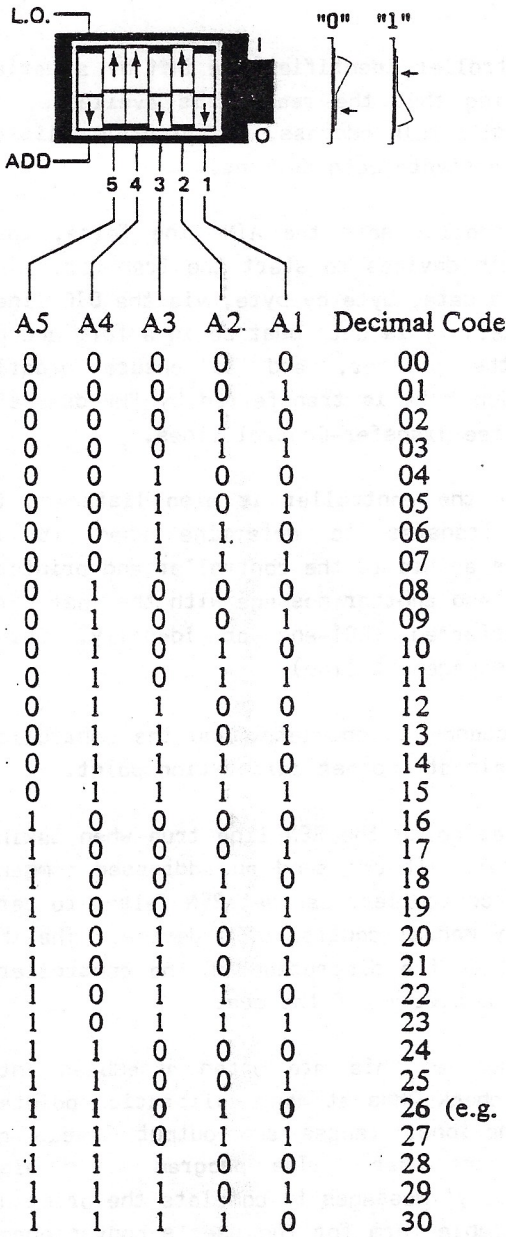

'Listener Only' (L.O.)

The sixth switch when set to L.O. causes the 4200 to become a 'Listener Only', meaning that it can only receive programming data. When set to ADD, the normal bus address may be used.

Addresses 0 - 30

With an address selected in the range 0 to 30 the instrument may be controlled manually, or remotely as part of a system on the Bus. The address selected must be the same as that used in the controller program to activate the 4200.

NB: The selected address can be temporarily displayed on the front panel when in manual control, by touching Error and then Guard.

Remote Operation

When the 4200 is operating under the direction of the controller, the legend *rem* appears on the mode display, and all front panel controls are disabled except Power and Safety Reset.

On entering remote, any earlier (manual) selection of Error mode is cancelled. During remote operation, the facilities of Error mode are excluded, as they can easily be programmed into the controller. Spec mode is also cancelled, but "Spec" information can be obtained by bus command. There is no Spec mode display on the front panel during remote operation.

The 4200 power-up sequence is performed as for manual operation. After power-up, and on recovery from a power failure, the 4200 generates an SRQ and prepares an "RQS Status Byte" for transmission to the controller as a response to its subsequent serial poll.

Calibration Enable

A 'Calibration Enable' command via the bus is required to set the instrument into its Remote Calibration mode (the CALIBRATION ENABLE keyswitch on the rear panel must already be set at ENABLE). Selection of any address 0 - 30 inhibits manual calibration from the front panel.

Address 31 (Illegal bus address)

This address configures manual operation only, inhibiting remote facilities. Address 31 must be selected (with CAL key set to ENABLE), for manual calibration to be carried out.

Table 5.3. Address Selection

Temporary Transfer to Local Operation (GTL)

The 4200 can be programmed to switch into "Local" operation (Command GTL), permitting a user to take manual control from the front panel. The system controller regains "Remote" control by sending the following overriding commands:

LAD With REN True

The controller addresses the 4200 as a listener with the Remote Enable management line true (Low). This returns the 4200 from local to remote control. Any commands which had been sent during the period under local control will then be executed.

SDC

Specific "Device Clear" commands are sent over the bus, returning the 4200 to a predetermined state (described later in this section).

Programming Instructions

Programming Strings

From the example given earlier in this section it is evident that the 4200 requires an address code followed by a series of device-dependent messages or commands to alter its configuration.

A series of these commands can be sent together as a "program string", each programming instruction being position-independent.

Each string will contain at least one programming instruction (detailed later in this section), but the 4200 must receive the string "terminator" before it can activate any instructions. The required terminator for the 4200 is the ASCII character "=".

e.g. programming instructions → string terminator
 → R4F301 =

To assist in eliminating incorrect programming instructions, the 4200 checks for errors in the string, and generates a service request (SRQ) if a syntax error occurs or if an option is called for but not fitted. To ensure that the programming string does not set up a prohibited state, it also checks the whole string for validity. If it finds any errors in this phase, the whole command string is ignored.

For Example:

With the 4200 set in 10mV Range, a string is received which contains an unacceptable command to switch Sense connection ("S" command). The user needs to set up a completely new, valid string; so the whole string is discarded.

Device-dependent commands

To give maximum scope for system programming, the bus operation of the 4200 differs in detail from manual operation, which is organised for ease of front panel use. Some functions of the 4200 firmware are deleted for bus operation, as they are easily programmed into the system controller; and extra functions have been made available to take advantage of the controller's added computing power.

The following Alphabetic codes are used to establish the required functioning of the 4200 as a calibration source:

- Full Range/Zero: A
- Safety Delay Override: D
- Output On/Off: O
- Function ACV, ACI: F
- Output Range in all Functions: R
- Output Value: M
- Frequency: H
- Spot Frequencies: T
- Sense: S
- Guard: G
- "Calibrate" trigger: C
- Calibration Mode Enable: W

The following Alphabetic codes are used to select and configure the messages to be passed by the 4200 via the IEEE Bus:

- Output string terminators: K
- Notation of output values: L
- Specification tolerances (relative:ppm or %): P
- Specification tolerances (absolute limits): U
- Recall/Verify (relative): V
- Service request origination: Q
- Diagnostic information: X

Fig 5.3 summarises the way that front panel functions are transferred to system operation, and Table 5.4 lists the range of device-dependent command codes available.

CONTROL	CODE	DESCRIPTION	
FULL RANGE/ZERO	A0	Zero.	
CALIBRATION MODE	A1	Full Range, but not if R0 set.	
	C0	"CAL" Calibration Trigger.	
	C1	"SCI")	
	C2	"SID") See Section 8.	
	C3	"PRCAL")	
SAFETY DELAY	D0	Safety delay active.	
	D1	Safety delay override.	
FUNCTION	F1	AC Voltage.	
	F3	AC Current.	
	G0	Local Guard.	
GUARD	G1	Remote Guard.	
	H***...	Numeric value of frequency (frequency always autoranges). Default state is 1kHz.	
FREQUENCY	I	Store next 16 ASCII characters, but excluding string terminator. (Calibration Key set to ENABLE).	
	K0	Cr followed by Lf with EDI.	
MEMORY (User's Aide-Memoire)	K1	Cr followed by Lf.	
	K2	Cr with EDI.	
	K3	Cr.	
	K4	Lf with EDI.	
	K5	Lf.	
	K6	EDI with last character.	
	K7	No terminator.	
VALUE NOTATION (Output to bus)	L0	Scientific plus legends.	
	L1	Scientific with no legends.	
	L2	Engineering plus legends.	
MAIN REGISTER	L3	Engineering with no legends.	
	M***...	Numeric value of Output setting. Default State is 10% Full Range.	
	O0	Output OFF.	
OUTPUT	O1	Output ON.	
	P0	24hr)	
SPECIFICATION TOLERANCE	P1	90 dy)	
	P2	1yr) Output uncertainty.	
SERVICE REQUEST	Q0	SRQ on all specified states.	
	Q1	SRQ on Overload and Fail only.	
OUTPUT RANGE	Q2	No SRQs.	
	R0	Output Autorange.	
	R1	----	
	R2	100µA	
	R3	1mA	
	R4	10mV	
	R5	100mV	
	R6	1V	
	R7	10V	
	R8	100V	
	R9	1000V	
	S0	Local Sense.	
	S1	Remote Sense.	
	SPOT FREQUENCIES	T0	Cancel Spot Frequency.
		T1	SF1) Select Spot Frequencies.
T2		SF2) (Frequencies depend on	
T3		SF3) Function and Output Range).	
T4		SF4) Function and Output Range).	
SPECIFICATION TOLERANCE (Absolute Limits or Uncertainty)	U0	24 hr)	
	U1	90 dy)	
	U2	1 yr)	
	U3	24 hr)	
	U4	90 dy)	
RECALL/VERIFY	U5	1 yr)	
	V0	4200 Output value.	
	V1	4200 Frequency setting.	
	V2	4200 Status (command codes).	
	V3	Software Status(Part No.--Issue).	
CALIBRATION	V4	F1)	
	V5	F2)	
	V6	F3) Recall "Stored" Frequency value.	
	V7	F4) Recall previously-entered Error Mode gain factor.	
	V8	F5)	
DIAGNOSTIC (Refer to Calibration and Servicing Handbook for description of correct process)	W0	Calibration Mode disable.	
	W1	Calibration Mode enable (if Cal Key first set to ENABLE).	
	X0	- Not used.	
	X1	Range gain correction string.	
	X2	"SID" Cal.Gain Factor.	
	X3	Zero Offset) Reference Divider	
	X4	Gain Factor) correction.	
	X5	- Not used.	
	X6	Corrected Reference Divider setting.	
	X7	Gain Factor at the selected Spot Frequency.	
X8	Recall User-defined message.		

Table 5.4 IEEE 488 Command Codes

CONTROL	CODE	DESCRIPTION
FULL RANGE/ZERO	A0	Zero.
CALIBRATION MODE	A1	Full Range, but not if R0 set.
	C0	"CAL" Calibration Trigger.
	C1	"SET" See Section B.
	C2	"STD" See Section B.
SAFETY DELAY	D0	Safety delay active.
	D1	Safety delay override.
FUNCTION	F1	AC Voltage.
	F3	AC Current.
GUARD	G0	Local Guard.
	G1	Remote Guard.
FREQUENCY	H***	Numeric value of frequency (frequency always autoranges). Default state is kHz.
	I	Store next 16 ASCII characters, but excluding string terminator. (Calibration key set to ENABLE).
MEMORY (User's Aide-Memoire)	K0	Cr followed by Lf with E01.
	K1	Cr with E01.
	K2	Cr.
	K3	Lf with E01.
	K4	Lf.
	K5	E01 with last character.
	K6	No terminator.
	K7	No terminator.
VALUE NOTATION (Output to bus)	L0	Scientific plus legends.
	L1	Scientific with no legends.
	L2	Engineering plus legends.
MAIN REGISTER	L3	Engineering with no legends.
	M***	Numeric value of Output setting. Default state is 10% Full Range.
	O0	Output OFF.
OUTPUT	O1	Output ON.
	P0	24hr) Output uncertainty.
SPECIFICATION TOLERANCE	P1	90 dy)
	P2	1yr)
SERVICE REQUEST	Q0	SRQ on all specified states.
	Q2	SRQ on Overload and Fail only. No SRQs.
OUTPUT RANGE	R0	Output Autorange.
	R1	100µA
	R2	1mA
	R3	10mV
	R4	10mA
	R5	100mV
	R6	1A
	R7	10V
R8	100V	
SENSE	S0	Local Sense.
	S1	Remote Sense.
SPOT FREQUENCIES	T0	Cancel Spot Frequency.
	T1	SF1)
	T2	Select Spot Frequencies.
	T3	SF2)
	T4	Select Spot Frequencies depend on
	T5	SF3) (Frequencies depend on SF4) Function and Output Range), SF5)
SPECIFICATION TOLERANCE (Absolute Limits of Uncertainty)	U0	24 hr)
	U1	90 dy)
	U2	1 yr)
	U3	Output Low Limit to bus.
	U5	Output High Limit to bus.
RECALL/VERIFY	V0	4200 Output value.
	V1	4200 Frequency setting.
	V2	4200 Status (command codes).
	V3	Software Status(Part No.--Issue).
	V4	F1)
CALIBRATION	V5	F2)
	V6	Recall "Stored" frequency value.
	V7	F3)
	V8	F4)
	V9	Recall previously-entered Error Mode gain factor.
DIAGNOSTIC (Refer to Calibration and Servicing Handbook for description of correct process)	W0	Calibration Mode disable. (if Calibration Mode enable (if Cal Key first set to ENABLE)).
	W1	Cal Key first set to ENABLE).
X0 - X8	X0	- Not used.
	X1	Range gain correction string.
	X2	"STD" Cal.Gain Factor.
	X3	Zero Offset) Reference Divider
	X4	Gain Factor) corrections.
	X5	- Not used.
	X6	Corrected Reference Divider setting.
	X7	Gain Factor at the selected Spot Frequency.
X8	Recall User-defined message.	

Table 5.4. 4200 IEEE 488 Command Codes

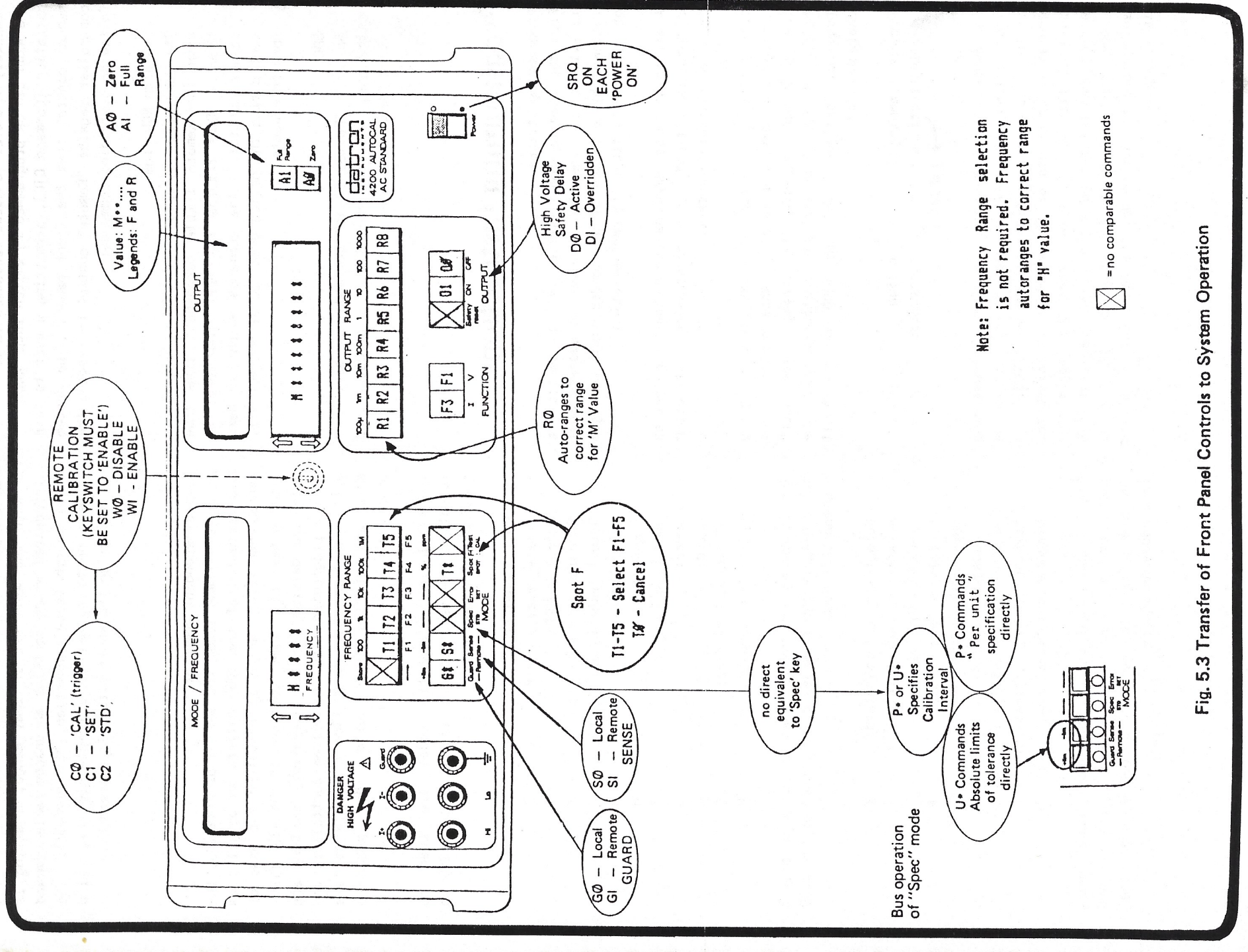
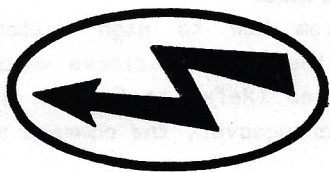

Fig. 5.3 Transfer of Front Panel Controls to System Operation

DANGER

HIGH VOLTAGE



FRONT or REAR
terminals carry the
Full Output Voltage.
THIS CAN KILL!

READ THIS: For manual operation, the 4200 High Voltage Interlocks ensure that users employ deliberate actions before voltages in excess of 75V are generated at the OUTPUT terminals. In System applications, the same interlocks require the same deliberate commands to be received from the system controller. (But see Safety Delay Override command D1 in the text).

In manual operation the user who is exposed to danger from high voltages also has direct control of the 4200 output, but it is not possible to give the same degree of built-in protection to exposed users when the instrument is under remote program control. This danger is intensified by the high speed of remote programming, so it is **ESSENTIAL** that **WHENEVER THE 4200 IS BEING USED IN A SYSTEM TO GENERATE VOLTAGES IN EXCESS OF 75V THERE MUST BE NO ACCESS TO THE 4200 FRONT PANEL OR REAR PANEL OUTPUT TERMINALS.**

Unless **you** are **sure** that
it is **safe** to do so,
DO NOT TOUCH the
I+ I- Hi or Lo leads
and **terminals**

DANGER

PROGRAMMING OF OPERATIONAL FUNCTIONS

OUTPUT ON/OFF

The analog OUTPUT is switched off by command `00` (output disable), and switched on to the selected value by `01`. The amplitude and frequency of the output are derived from the 'M' code and 'H' code data used to set the "Main" (OUTPUT display), and "Auxilliary" (MODE/FREQUENCY display) registers, respectively.

Safety Delay

The High Voltage Safety delay (3 seconds) is normally active (`D0`). It can be overridden by the command `D1`, but the use of this command sets up potentially dangerous situations. `D0` is enforced by any Function or Range change (including Autorange changes).

WARNING

DO NOT USE D1 UNLESS IT IS ESSENTIAL FOR HIGH SPEED OPERATION. TAKE SAFETY PRECAUTIONS TO PROTECT PERSONNEL IN THE VICINITY.

Function

`F1` (AC Voltage) and `F3` (AC Current) configure the instrument to the required function.

Output Range

`R1` through to `R8` configure the 4200 to specific ranges as shown earlier in Table 5.4. `R0` places the instrument in auto-range function, allowing the output value to be specified as a number without setting the actual range. Ranging down occurs at 20% of range, i.e. Full Scale value of next lower range. Ranging up occurs at Full Scale. In autorange, commands `A0` and `A1` are invalid.

Output Display Value (Main Register)

In remote programming, the incremental (`+/+`) method of setting the output value is not used. Instead, Code `M*****` is used to set the output value explicitly, either in numeric, scientific or

engineering notation (See Examples below). If the resolution is too high, the value is truncated to the correct resolution and the controller is informed by `SRQ` and `RQS` Status byte (see `SRQ` status byte formats later in this section).

High Voltage Outputs

The change from Low to High voltage state is controlled by the same interlocks which govern the manual changeover (Refer to Section 4, page 4-7). To effect the changeover, the command string:

`"M (followed by voltage) 01 = "`

should be used if OUTPUT is already on and a range change is not involved. If a range change is programmed to set the output into high voltage state (for instance in `R0`) the "01" should be sent as a separate string.

If the M code alone is attempted (`M****... =`) with OUTPUT already enabled (`01`), the new value is set in the Main Register (OUTPUT display); but the output voltage will not ramp to high voltage state until the enabling string "01 =" is received.

If the attempt had been made with OUTPUT disabled (`00`), then `01` would be required in any case.

It should also be remembered that the AC output circuitry needs time to settle to its final value, especially if a range-change is incurred. Delays should be included in the controller program to allow for this.

During these processes, the front panel warnings of flashing LEDs and pulsing tones operate as for manual operation. Nevertheless, access to the front panel should be restricted because the high speed of programming in the IEEE interface adds to the safety hazard.

Examples of valid M codes:

Required Output Value	Function	Range	M Code	Output Display
153V	F1	R7	M153	153.000,0V
1.621257V	F1	R5	M1.6212574	1.621,257V (truncation to 6½ digits)
1.621257V	F1	R5	M1621257E - 6	1.621,257V
1.621257V	F1	R0	M1621.257E - 03	1.621,257V (Autorange to R5 = 1V)
0.002563A	F3	R0	M.002563	2.56300mA (Autorange to R3 = 10mA)

Output Resolution.

The output resolution conforms to the following number of digits:

Ranges	100 μ	1m	10m	100m	1	10	100	1000
Range Codes	R1	R2	R3	R4	R5	R6	R7	R8
Functions:								
AC Voltage F1	--	4 $\frac{1}{2}$	5 $\frac{1}{2}$	6 $\frac{1}{2}$	6 $\frac{1}{2}$	6 $\frac{1}{2}$	6 $\frac{1}{2}$	6 $\frac{1}{2}$
AC Current F3	6 $\frac{1}{2}$	6 $\frac{1}{2}$	6 $\frac{1}{2}$	6 $\frac{1}{2}$	6 $\frac{1}{2}$	--	--	--

Frequency Display Value (Auxilliary Register)

In remote programming, the incremental (\uparrow/\downarrow) method of setting the frequency is not used. Instead, each auxilliary register value is input explicitly by Code H***... in numeric, scientific or engineering notation.

The manual frequency "Store" memories cannot be set via the bus, although their contents can be read using "V" codes.

Frequency Resolution

The 4200 Frequency is resolved to three significant digits (1% / 100ppm accuracy). On the display this will occupy four digit spaces, to accommodate the decimal point. If the significance is greater than three digits, the value is truncated and the controller is informed by SRQ Status byte (see SRQ status byte formats later in this section).

Frequency and Voltage Constraints

On 100V and 1000V output ranges, the 4200 will refuse any command for an output which exceeds the limits defined on page 3-6. The controller is informed by "Error 7" SRQ status byte (see SRQ status byte formats later in this section).

Spot Frequency Selection

Codes T1-T5 select the spot frequencies stored in FS1-FS5 non-volatile memories. Sixty unique memory locations exist. Thirty-five are allocated to the seven Voltage output ranges and twenty-five to the five Current ranges: five for each range. The value of the frequency called up by any T command is therefore dependent on the preselected F and R codes.

With spot active, sending a new R code selects the corresponding spot frequency in the new range. Sending a new F code to change function cancels the T command: the 4200 frequency reverts to 1kHz.

The controller is able to command an uncalibrated spot. The "uncalibrated" message is displayed as

in manual operation, the 4200 frequency remaining as previously set. But in addition, the 4200 generates an SRQ to notify the controller. Code T0 cancels any earlier spot frequency selection: the 4200 frequency reverts to 1kHz.

NB. The Spot Frequency facility is included to provide separate, ultra-accurately calibrated points in the 4200 output spectrum. Therefore, the frequencies set into the "spot frequency" memories can only be changed as part of the Autocal routine.

Guard and Sense

These are configured into Local or Remote by G and S codes:

G0 - Local Guard

G1 - Remote Guard

S0 - Local Sense (forced when F3 has been commanded, and when F1 with R2, R3, or R4 has been commanded).

S1 - Remote Sense (available only when F1 with R5, R6, R7, or R8 has been commanded).

These bus commands are subject to the constraints of the 4200 firmware. The instrument will reject and ignore invalid commands, such as Remote Sense when in 100mV range.

Calibration Enable and Calibrate (W and C codes)

These are available for automatic calibration of the 4200, under remote control via the IEEE bus. Refer to the Calibration and Servicing Handbook.

W0 - Calibration disable.

W1 - Enable (only if CALIBRATION ENABLE keyswitch set to ENABLE).

C0 - Calibration Trigger -)

equivalent to CAL key.) Refer to

C1 - As SET key.) Section 8.

C2 - As STD key.)

Programming of Bus Transmissions

Output String Formation

The 4200 can be commanded to output "internal" information to the system via the IEEE 488 bus, by sending one of the specified "recall" messages.

Only one recall command should be included in a terminated string.

As well as the information it contains, the string needs to be formatted correctly for acceptance by the system. Many variations of format are available; These can be programmed for the type of system in use.

The length and construction of the string both depend upon the type of information to be transmitted, and thus upon the codes used to program the 4200. The purpose of this explanation is to describe the effects of these codes on the output string format.

Figure 5.4 illustrates the construction of a typical string, such as the 4200 output value. Notice that numerical data is reduced to a standard form, and scaled by means of an exponent in base 10. All device-dependent messages use the ASCII code.

Figure 5.4 Breakdown of a Typical Output String

(This is a general example - two specific 4200 examples appear on p5-12)

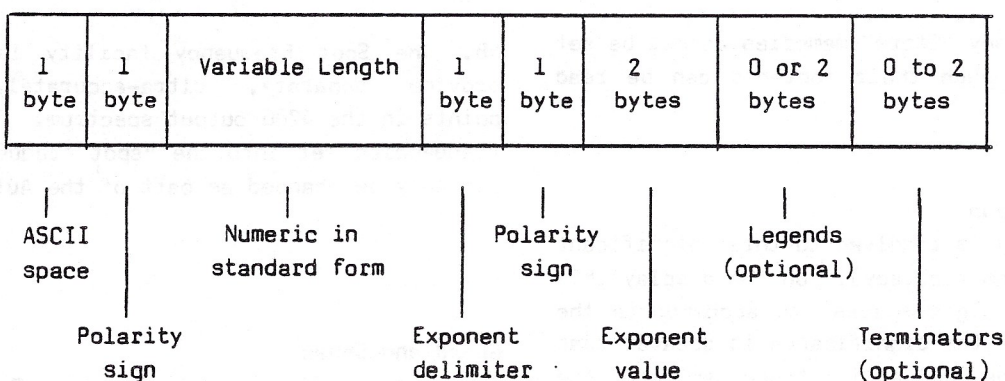

ASCII "space".

A format character to denote the beginning of an output string - not present for recall command X8.

Polarity sign.

Replaced by an ASCII space in the 4200. In instruments with DC functions, the appropriate polarity sign is presented.

Numeric sub-string.

Length depends on the resolution of the information to be transmitted, and form depends on the notation programmed by "L" code.

Exponent delimiter "E".

Signifies that the numeric has finished and the next three bytes form the exponent.

Exponent value.

The first of the three bytes is always '+' or '-'. Because the value is never greater than 9, the second byte is always 0, and the third is a single decimal digit.

Legends.

Inclusion is optional, but if they are programmed in, two bytes are always present. The characters are appropriate to the programmed state of the 4200.

Terminators.

Two terminating characters are available, as programmed by "K" code. The EOI bus management line can optionally be programmed for simultaneous transmission with the last byte of the string.

Format Codes

The following pages list and describe the programming codes which determine the formation of the output string. The codes on page 5-11 select specific types of ASCII strings for retrieval.

Recall/Verify (code V).

By sending a V code the controller interrogates the 4200 to obtain information about its present status. Unless otherwise stated, the output strings are formatted as programmed by K and L codes. The V codes are as follows:

V0 - The present Output value.

V1 - The present Frequency setting.

V2 - The present functional status.

The response to V2 is a standard ASCII string:

(space R*F*O*G*S*W*Q*D*L*K*T* terminator)

The functions are represented by the same numerics as for programming. In addition the Output Range is identified by a lower case 'r' if the 4200 is programmed in autorange.

V3 - Software status.

The software status is the part number and issue number of the internal program. This is formatted as follows, in response to command code V3:

(space 890052 - numeric terminator)

Part No. Issue No.

(This status report is also available manually by pressing Error key then Lim-. The firmware issue-number is presented on the MODE display).

V4 to V8 - 'Stored' Frequencies.

Codes V4 to V8 recall each of the five frequencies held in volatile memory locations F1 to F5. These can only be set or selected manually. (Refer to page 3-6).

V9 - Error Mode gain factor.

Error Mode cannot be programmed via the IEEE bus; but the gain factor which was produced at the most recent manual use of Error Mode is still retained in volatile memory. Code V9 can be used to recall this gain factor.

The range of legends transmitted by the 4200 is listed under "Notations and Legends (L codes)".

Specification Tolerance (Per unit - P codes).

The P commands give access to Spec mode over the bus, also setting the calibration interval:

P0 - 24 hour; P1 - 90 day; P2 - 1 year.

On being commanded by P code, the 4200 calculates the Output Uncertainty of its current state (as a "per unit" fraction of the output value) and generates an output string formatted by K and L codes. Legends are transmitted as pu (per unit).

Absolute Limits of Tolerance.

In this case, the U commands cause the 4200 to calculate the high or low limit of uncertainty of its output value against the nominated calibration interval:

U0 - Low limit 24 hour

U1 - Low limit 90 day

U2 - Low limit 1 year

U3 - High limit 24 hour

U4 - High limit 90 day

U5 - High limit 1 year

On being commanded, the calculated value is output by the 4200 in an output string formatted by K and L codes.

Diagnostic Information

The X commands recall the contents of certain non-volatile calibration memory locations. The values recalled are calibration constants stored at the most recent Autocalibration. They are used in the computations which establish the 4200 output level, as corrections for long-term drift in the analog circuitry.

X0 - Not used in 4200

X1 - Range gain correction string, comprising:

a. LF gain factor

b. HF calibration factor

X2 - 'STD' calibration gain factor

X3 - Zero offset)

X4 - Gain factor) Reference Divider corrections

X5 - Not used in 4200

X6 - Corrected Reference Divider setting

X7 - Gain factor at the selected 'Spot' frequency.

X8 - Recall message which was memorised earlier by the operator using Code I.

Activating the Recall Transmission.

The 4200 assembles the appropriate output string in its output registers in response to the V, P, U, or X command. It can subsequently be released onto the bus by addressing the 4200 as a talker.

String Formatting Commands (K and L Codes).

The output string can be formatted and terminated to adapt to user's requirements. Scientific or Engineering notation can be programmed, with or without descriptive Legends. Two examples are given below.

b. The EOI bus management line can be programmed to set true simultaneously with the last byte of the string. EOI can be used even if both Cr and Lf are suppressed.

Codes L0 to L3 configure the output string notation:

- L0 - Scientific notation with legends
- L1 - Scientific notation, no legends
- L2 - Engineering notation with legends
- L3 - Engineering notation, no legends

The 4200 can also be programmed to transmit strings without terminators. To accommodate these variations, the system programmer uses the K codes:

- K0 - No suppression (Cr, Lf and EOI all present as terminators)
- K1 - Suppress EOI (Terminator Cr Lf)
- K2 - Suppress Lf (Terminator Cr with EOI)
- K3 - Suppress Lf and EOI (Terminator Cr)
- K4 - Suppress Cr (Terminator Lf with EOI)
- K5 - Suppress Cr and EOI (Terminator Lf)
- K6 - Suppress Cr and Lf (Terminator EOI with last character)
- K7 - Suppress Cr, Lf and EOI (No terminators used)

Two sorts of terminator are available:

- a. One or two bytes can be added to the end of the string. These contain either Carriage Return (Cr) or Line Feed (Lf); or both in the order: Cr followed by Lf.

Examples of Typical 4200 Output Strings:

1. Scientific Notation (Codes L0 and L1).

Bytes - 1 2 3 4 5 6 7 8 9 10 11 12 13 14 15 16 17 18

Sp	Sp	0/1	.	0-9	0-9	0-9	0-9	0-9	0-9	E	+/-	0	0-9	V/A		Cr	Lf
----	----	-----	---	-----	-----	-----	-----	-----	-----	---	-----	---	-----	-----	--	----	----

Two ASCII spaces

Output Value Numeric: 0.000000 to 1.999999

Output Value Exponent: ±(0 to 9)

Legend(s): (In this case code L0 was programmed.)

Terminator(s): (Code K1 programmed)

2. Engineering Notation (Codes L2 and L3).

Bytes - 1 2 3 4 5 6 7 8 9 10 11 12 13 14

Sp	Sp	0/1	0-9	0-9	0-9	0-9	0-9	0-9	0-9	E	+/-	0	0
			/	/	/								/3
			.	.	.								/6

Two ASCII spaces

Output Value Numeric: 0.000000 to 199.9999

Output Value Exponent: ±(10⁰/10³/10⁶)

Legend(s): (In this case L3 was programmed.)

Terminator(s): (Code K6 programmed.)

EOI - EOI line set true with last byte

Descriptive Legends.

The following Legends will be fitted into the string after the exponent, if programmed by codes L0 or L3:

Recall	Function	Legend	Meaning	Recall	Legend	Meaning
V0, U0-U5	F1	V	AC Volts	P0-P2	pu	per unit
V0, U0-U5	F3	I	AC Amps	V9	pu	per unit
V1, V4-V8	T0	Hz	Hertz			
V1, V4-V8	T1-T5	Sf	Spot freq. (Hz)			

Service Request

The 4200 can asynchronously request service from the controller by putting the SRQ line true (low). SRQ is always generated by the action of switching the 4200 power ON, as the power-up default mode is Q0.

A user can program the 4200 to generate SRQs (or not) using command code Q:

Code Q0 - SRQ on any of the states in table 5.5
 Q1 - SRQ on overload and any FAIL state in table 5.5

Q2 - No SRQs generated

Serial Poll and RQS Status Byte.

If programmed for SRQ response, the bus controller will pause in its operation to attend to the service request. It first conducts a serial or parallel poll to determine which device initiated the SRQ. The 4200 does not react to parallel poll, but only to serial poll, during which each device is addressed in turn. The instrument responds to its serial-poll address by releasing a prepared "RQS Status Byte" on to the bus. The RQS Request Bit (bit b7 of its status byte) is set true (Low) only if the 4200 has generated the SRQ. This validates the remainder of the byte, which describes the causal condition by the state codes listed in Table 5.5.

RQS Status Byte Composition:

- bit b8: Indicates an option or syntax error when true.
- bit b7: The RQS request bit, when true, admits that the 4200 was the SRQ originator. The RQS status byte is not valid unless bit b7 is true.
- bit b6 true: Each combination of bits b5-1 represents a single state as listed in Table 5.5.
- bit b6 false: Bits b5-1 each represent separate functional states within the 4200, and the RQS byte represents several states as listed in Table 5.5.

Example with bit b6 false:

- RQS status byte 01000001 represents:
- 0 - No option or Syntax error.
- 1 - This instrument originated the SRQ.
- 0 - The following bits each represent separate states.
- 0 - This bit is not used in the 4200.
- 0 - No High voltage warning.
- 0 - Auxiliary register not at limit.
- 0 - Main register not at limit.
- 1 - Output is ON.

The RQS status byte should not be confused with other status messages (e.g. 'calibrator' or 'software' status, described earlier under 'Recall/Verify') which are called up by the system controller's program.

DIO Line Transmissions.

Providing Q0 or Q1 has been selected; when the 4200 has a message to transmit over the DIO lines, it sets the SRQ line true and prepares the "Recall" RQS status byte (x1100000) ready for the subsequent serial poll. On receiving the status byte, the controller can address any device required to receive the data as a listener, and address the 4200 as a talker. Then the message will be passed via the DIO lines to the programmed listener(s).

Fail Messages.

The 4200 needs to react quickly to internally-generated FAIL messages and is programmed to take rapid protective action. A fault condition may generate a train of such internal messages, which occur too quickly for some controllers to detect.

Such a train may be terminated by a FAIL 5 message, which is detected by the controller. Therefore the receipt of a FAIL 5 message by a controller should be taken as a final default condition, and not as indicating the origin of the fault. The FAIL 5 message can be cleared, if the 4200 has recovered, by pressing the Safety Reset key on the instrument front panel. As FAIL 5 is related to safety, it cannot be reset by remote control.

Table 5.5 lists the possible RQS status bytes which may be transmitted by the 4200. The information in the byte is valid only if bit b7 (request bit) is true.

		Legend: 1 = True, 0 = False, X = 1 or 0							
bits		b8	b7	b6	b5	b4	b3	b2	b1
Option or Syntax error		1	1	X	X	X	X	X	X
RQS Request-for-service bit		X	1	X	X	X	X	X	X
Combination Status Messages									
X	1	0	X	X	X	X	X	1	1
X	1	0	X	X	X	X	1	X	X
X	1	0	X	X	X	1	X	X	X
X	1	0	X	1	X	X	X	X	X
Individual Status Messages									
X	1	1	0	0	0	0	0	0	0
X	1	1	0	0	0	0	0	1	1
X	1	1	0	0	0	1	0	1	0
X	1	1	0	0	0	1	1	1	1
X	1	1	0	0	1	0	0	0	0
X	1	1	0	0	1	0	1	0	0
X	1	1	0	0	1	1	0	1	0
X	1	1	0	0	1	1	1	1	0
X	1	1	0	0	1	1	1	1	1
X	1	1	1	0	0	0	0	0	0
X	1	1	1	0	0	0	0	1	1
X	1	1	1	0	0	1	0	1	0
X	1	1	1	0	1	0	0	1	1
X	1	1	1	0	1	0	0	0	0
X	1	1	1	0	1	0	1	0	0
X	1	1	1	0	1	0	1	0	1
X	1	1	1	0	1	1	1	1	1
X	1	1	1	1	0	1	1	1	1
X	1	1	1	1	0	1	1	1	1
X	1	1	1	1	1	0	0	0	0
X	1	1	1	1	1	0	0	1	0
X	1	1	1	1	1	0	0	1	1
X	1	1	1	1	1	1	0	0	1
X	1	1	1	1	1	1	1	1	1
X	1	1	1	1	1	1	1	1	1
X	1	1	1	1	1	1	1	1	1

Table 5.5 Status Byte Coding

NOTES:

- (1) Power-up condition:
 D# F1 G# H(1KHz) K#* L#* M(L#%FR) O# Q# R#(1.0V) S# T# W#
- *Device clear condition as power-up but K# and L# continue unchanged.
- (2) Program string terminator: "=" activates preceding string.

Activation of Commands

Use of Terminator.

The 4200 does not activate commands, whether single or multiple, unless the recognised terminator is received. This is the ASCII character "="

Commands or command strings may be received while the instrument is in Local control, but will not be activated even if a terminator is present, until the instrument is set to remote control. The two "Clear" messages (DCL and SDC) will be activated even when in Local control.

Multiple Commands

Activation sequence

The input buffer has a capacity of 128 characters. Commands in a multiple string may be entered in any order, provided correct character syntax is observed. They are extracted from the buffer in received sequence and stored by alpha character into command stores. Any existing commands on the store are over-written and lost.

When a string terminator is received, the commands in the store are validated. Validation ensures that the proposed instrument state (consisting of those changes programmed and those current states not reprogrammed) is valid. Any error results in the string being ignored and a syntax error generated.

New commands are executed in this sequence:

- L Output notation
- K Output terminator format
- Q SRQ Mode
- W Remote Calibration Enable
- I User message input
- O~~U~~ OUTPUT OFF
- S Sense
- G Guard
- D Safety Delay override
- F Function
- R Range
- A Full Range / Zero
- T Spot Frequency selection
- M Main Register value (Output)
- H Auxilliary Register value (Frequency)
- O~~I~~ OUTPUT ON
- C Calibrate Mode
- P Specification tolerance
- U Specification limits
- V Recall/Verify
- X Diagnostic information

A programmer may elect to change the sequence by

inserting terminators between commands, but the basic constraints of the 4200 will still be imposed. For example, if the function is changed as a single command (e.g.F3=) the main program firmware will set Output OFF as a result, and it must then be re-programmed ON by the user.

Succession of Multiple Commands.

If the input buffer is not full, new commands are accepted to await their turn for processing, and are extracted string by string. The input system design makes it extremely unlikely that the buffer will overflow, unless the 4200 is in Local Control and the command input is excessive. If this does cause the buffer to fill up, the 4200 places a hold on the IEEE bus handshake sequence. The command IFC can be used to release the hold, followed by DCL to clear the 4200 input buffer; but as a general principle, this situation should be avoided by suitable reprogramming.

Input Errors

Some unwanted commands are entered in the input buffer and rejected later, but others are ignored entirely.

"Read" commands.

Before addressing the 4200 as a talker, it is essential that it has been programmed by a P, U, V or X command. Otherwise it will have no data to transmit.

Universal commands

- LLO (Local Lockout) - ignored, no capability
- PPU (Parallel Poll - ignored, no capability for Unconfigured) parallel poll
- SPE (Serial Poll) - will set the instrument to serial poll state, and when addressed will respond with the RQS status byte. This byte contains the condition of the request-service bit (bit7). If the 4200 is requesting service; bit 7 will be true, and the other bits will describe the service required.
- SPD (Serial Poll - returns the instrument to Disable) serial poll idle state.

Addressed commands

- PPC (Parallel Poll - ignored, no capability configure)
- GET (Group Execute - ignored, no capability Trigger)
- TCT (Take Control) - ignored, no capability
- GTL (Go To Local) - instrument returns to Manual Control. The controller regains remote control by addressing the 4200 as a listener with REN line true.

Clear Commands (DCL and SDC)

When the 4200 receives either of the two 'Clear' messages, (DCL is universal and SDC is addressed to a selected device) it will default to the pre-determined state defined below. During the time taken to default, the IEEE interface handshake is held. These commands are effective even in "Local" control.

- A? Not Active (see M code)
- F1 AC volts
- R0 Autorange 10VAC default
- M(value) Where value is 10%FR(1V)
- T0 Cancel Spot Frequency
- H(value) Where value is kHz
- G0 Local guard
- S0 Local sense
- O0 OUTPUT OFF state
- Q0 SRQ on all specified states
- D0 Safety delay active
- W0 Calibration disabled
- C? Not active - disabled by W0
- P? Not active
- U? Not active
- V? Not active
- X? Not active
- K* Unchanged
- L* Unchanged

The frequency values held in 'Store' volatile memory locations F1-F5 are reset to the default state described on page 3-6.

Operational Sequence Guidelines

Most interface communication tasks require sequences of coded messages to be sent over the interface. Many controllers assign a single programming instruction to a complete sequence, so it is advisable to study the available controller capabilities carefully before attempting to program a system. Because the IEEE Std 488 (1978) allows a certain latitude in bus protocol, considerable differences may be found between programming instructions and operating sequences from one make of controller to another. Consequently, the following sequences are recommendations only.

Data Transfer

- UNL Inhibits all current listeners
- LAD₁ Each address sent enables a specific device to receive future data bytes.
- LAD_n More than one address may be sent if multiple listeners desired.
- TAD The address sent enables a specific device to send data. NB. The 4200 must be already programmed to prepare data.
- DAB₁ Data bytes sent by currently-enabled talkers to all currently-enabled listeners.
- DAB_n
- UNT Disables the talker on receipt of the last character.

- UNL = unlisten
- LAD = listen address of specific device
- TAD = talk address of specific device
- DAB = data bytes
- UNT = untalk

Serial Poll

- UNL Inhibits all current listeners
- SPE Puts interface into serial poll mode during which all devices send status instead of data when addressed.
- TAD_n Enables a specific device to send status. Within this loop devices should be sequentially enabled.
- SBN or SBA Status byte sent by enabled device: If SBN, loop should be repeated. If SBA sent, the enabled device is identified as having sent SRQ and will automatically remove it.
- SPD Disables serial poll mode.
- UNT Disable last talker.

- SPE = Serial poll enable
- SPD = Serial poll disable
- SBN = Status byte negative where bit 7 = 0
- SBA = Status byte affirmative where bit 7 = 1

Untalk

It is highly desirable that a sequence which causes a device to be addressed as a talker should be terminated by an "untalk" command.

SECTION 6 SPECIFICATIONS

General

POWER SUPPLY

Voltage : 100/120/220/240V $\pm 10\%$
Line Frequency : 48Hz to 62Hz
Consumption : 400 VA normal
650 VA full power
Fuses 220/240V : 3.15A
100/120V : 6.25A

ENVIRONMENTAL CONDITIONS

Operating temperature: 0°C to +50°C
(except where specified)
CAUTION. Above 30°C on 1kV Range: maximum output power available only intermittently.
Storage Temperature: -40°C to +70°C
Maximum Relative Humidity: 75% @ 40°C
Warm-up Time: One hour to meet all specifications

MECHANICAL

Dimensions : Height 178mm (7")
Width 455mm (17.9")
Depth 564mm (22.2")
Weight : 35Kg (77lbs)

OPERATING INDICATIONS

Indication : Symbols lit on displays and illuminated keys

Scale Lengths

Output Display : 6½ Digits maximum
(e.g. 1.999999V)

SAFETY : The 4200 has been designed to meet BSI 4743, IEC 348 and UL 1244 specifications

Frequency Display : 3 Digits plus store location.

Mode Display : 6½ Digits maximum
(Spec mode 'lim')

PEAK TERMINAL VOLTAGES

Guard to Ground : 920V (2.5kV flash test).
Lo to Guard : 920V
Lo to Ground : 920V
Hi to Guard : 1556V
Hi to Ground : 1556V
Rear panel Digital Inputs -
to Hi : 1556V
to Lo : 920V
to Guard : 920V
to Ground : 0V to +5V.

N.B.

Digital Common is internally connected to Ground.

AC VOLTAGE[7][9]

Scale Lengths; 1mV - 100V Ranges: 9% to 200% of Range,
1000V Range: 9% to 110% of Range.

RANGE	FREQUENCY Hz	STABILITY [2]			SPOT FREQUENCY FULL RANGE ACCURACY RELATIVE TO CALIBRATION STANDARDS $\pm(\text{ppm output})$ [1]		SPOT CALIBRATION UNCERTAINTY $\pm(\text{ppm} + \mu\text{V})$ [3]
		$\pm(\text{ppm Output} + \text{ppm FS})$ [4]			$23^{\circ}\text{C} \pm 5^{\circ}\text{C}$		
		10 Min	24 Hour	90 Day	90 Days	1 Year	
1.0000mV to 100.0000mV	10 - 31	5 μV	60+ 5+5 μV	80+ 10+5 μV	100 + 5 μV	120 + 5 μV	50 + 1
	32 - 330	5 μV	30+ 5+5 μV	40+ 10+5 μV	60 + 5 μV	90 + 5 μV	50 + 1
	300 - 10k	5 μV	20+ 5+5 μV	30+ 10+5 μV	50 + 5 μV	70 + 5 μV	50 + 1
	10k - 33k	5 μV	20+ 5+5 μV	30+ 10+5 μV	50 + 5 μV	70 + 5 μV	200 + 1
	30k - 100k	5 μV	30+ 5+5 μV	40+ 10+5 μV	60 + 5 μV	80 + 5 μV	500 + 1
	100k - 330k 300k - 1M	5 μV 5 μV	80+10+5 μV 130+10+5 μV	150+ 20+5 μV 300+100+5 μV	200 + 5 μV 500 + 5 μV	350 + 5 μV 0.1% + 5 μV	600 + 1[6] 800 + 1[6]
1.000000V and 10.00000V	10 - 31	20 + 5	40 + 10	50 + 10	60	80	50
	32 - 330	5 + 2	20 + 5	30 + 10	50	60	20
	300 - 10k	3 + 1.5	15 + 5	20 + 10	40	50	20
	10k - 33k	3 + 1.5	15 + 5	20 + 10	40	50	30
	30k - 100k	3 + 1.5	20 + 5	30 + 10	50	60	50
	100k - 330k 300k - 1M	5 + 2 7 + 3	50 + 10 120 + 10	70 + 20 300 + 100	100 500	150 0.1%	300 400
100.0000V	10 - 31	20 + 5	40 + 10	50 + 10	60	80	50
	32 - 330	5 + 2	20 + 5	30 + 10	50	60	20
	300 - 10k	3 + 1.5	15 + 5	20 + 10	40	50	20
	10k - 33k	3 + 1.5	15 + 5	20 + 10	40	50	30
	30k - 100k	3 + 1.5	20 + 5	30 + 10	70	80	50
	100k - 200k	5 + 2	50 + 10	70 + 20	150	200	200[6]
1000.000V 750V	45 - 330	10 + 3	50 + 10	70 + 20	80	130	50
	300 - 10k	5 + 2	30 + 10	40 + 20	60	100	60
	10k - 33k	5 + 2	50 + 15	60 + 20	80	120	100
	30k - 100k	10 + 3	80 + 20	120 + 40	150	200	500

OTHER SPECIFICATIONS

Settling Time to 100ppm of Step Size	10 - 31Hz <10s	32 - 330Hz <3s	>330Hz <1s
Minimum Load Resistance } in 4-wire Connection	Ten times total resistance of I+ and I- leads, Absolute Minimum 20R.		
Maximum Load Capacitance	1000pF. However, drive limited by output current (see graph opposite).		
Frequency Accuracy	<100ppm; typically <10ppm.		
Frequency Constraints	Refer to graph on page 3-6		
Voltage Sensing	Selectable remote or local sensing on 1V to 1000V ranges		
Guarding	Selectable remote or local Guard connection. Max. Guard to Ground voltage 650VRMS (2.5kV flash test).		
Common Mode Rejection	140dB at DC to 400Hz		

- Notes:
- [1] - For other than Full Range add: ('Wideband' ppm FS) x (Full Range - Output)/(Output)
 - [2] - For same conditions between 18°C and 28°C.
 - [3] - Includes factory traceability to National Standards and National Standards uncertainty. Datron Instruments traceability approx. SPOT/2.
 - [4] - FS = 2 x Nominal Range.
 - [5] - Predominantly second harmonic; negligible error on mean-sensing instruments
 - [6] - Estimated, not fully traceable.
 - [7] - Assumes typical thermal transfer measurement.
 - [9] - Above 100kHz it is advisable to use 4-wire connection. This will reduce the possibility of inaccuracies caused by reactances of external and internal 2-wire connections.

WIDEBAND ACCURACY RELATIVE TO CALIBRATION STANDARDS		WIDEBAND CALIBRATION UNCERTAINTY $\pm(\text{ppm} + \mu\text{V})$ [6]	TEMPERATURE COEFFICIENT $\pm\text{ppm}/^\circ\text{C}$ ($8^\circ\text{C}-18^\circ\text{C}$ and $28^\circ\text{C}-40^\circ\text{C}$)	TOTAL HARMONIC DISTORTION % [5]	OUTPUT	
$\pm(\text{ppm Output} + \text{ppm FS})$ [4] 90 Days 1 Year					ZERO TO FULL LOAD REGULATION	OUTPUT CURRENT
150+ 30+5 μV	170+ 30+5 μV	50 + 1	5	0.1	Output Resistance: 10R at all Frequencies	--
110+ 20+5 μV	120+ 30+5 μV	50 + 1	5	0.04		
100+ 20+5 μV	110+ 30+5 μV	50 + 1	5	0.04		
110+ 20+5 μV	120+ 30+5 μV	200 + 1	5	0.04		
150+ 20+5 μV	180+ 30+5 μV	500 + 1	5	0.1		
450+100+5 μV	550+100+5 μV	600 + 1[6]	20	0.3		
0.2%+0.1%+5 μV	0.3%+0.1%+5 μV	800 + 1[6]	50	1.0		
120 + 20	140 + 30	50	3	0.1	Typically 0.001% to 33kHz increasing to 0.2% at 1MHz	1V range - 25mA 10V range - 60mA
80 + 10	90 + 20	40	3	0.04		
70 + 10	80 + 20	40	3	0.04		
70 + 10	80 + 20	50	3	0.04		
120 + 20	150 + 20	80	3	0.1		
400 + 100	500 + 100	300	10	0.3		
0.2% + 0.1%	0.3% + 0.1%	600	50	1.0		
120 + 20	140 + 30	50	3	0.1	Typically 0.001% to 33kHz increasing to 0.01% at 200kHz	120mA
80 + 10	90 + 20	40	3	0.04		
70 + 10	80 + 20	40	3	0.04		
70 + 10	90 + 20	50	3	0.04		
150 + 20	160 + 20	80	5	0.2		
450 + 100	550 + 100	300	20	0.3		
120 + 25	180 + 25	50	5	0.2	Typically 0.001% to 33kHz increasing to 0.005% at 100kHz	<1kHz- 15mA >1kHz- 65mA
100 + 25	140 + 25	60	5	0.1		
150 + 25	180 + 25	100	5	0.1		
850 + 50	0.1% + 50	500	7	0.5		

Volt-Hertz power limit Versus Capacitance Load (1kV Range)

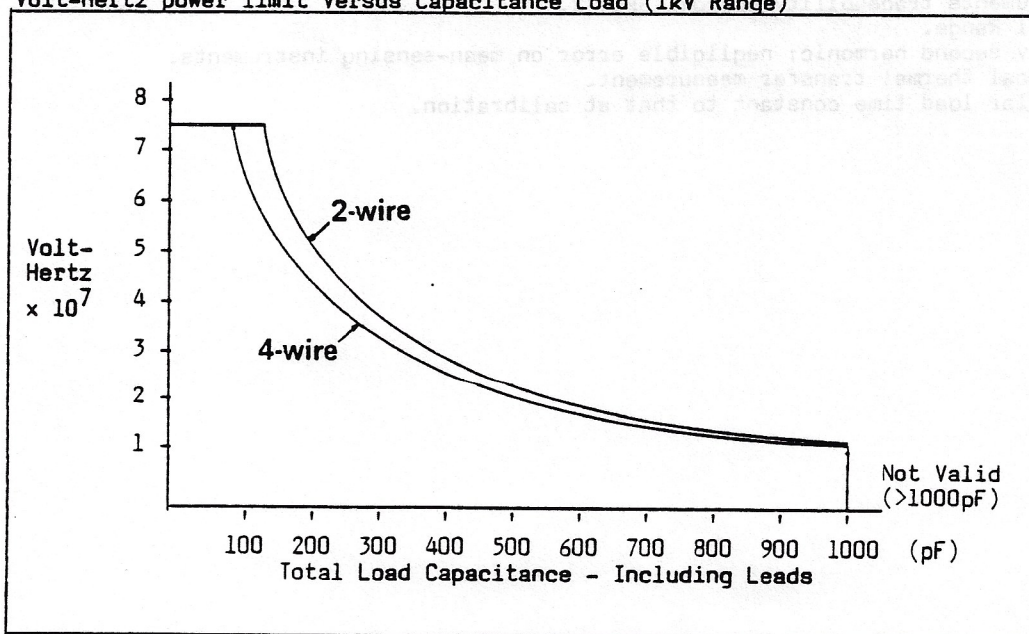

AC CURRENT^[7]

Scale Length: 9% to 200% of Range

RANGE	MAXIMUM LOAD RESIST.	FREQUENCY Hz	STABILITY [2]			SPOT FREQUENCY ACCURACY AT FULL RANGE RELATIVE TO CALIBRATION STANDARDS	
			±(ppm Output + ppm FS) [4]			±(ppm Output) [1] 23°C ± 5°C	
			10 Min	24 Hour	90 Day	90 Days	1 Year
100.0000µA	15kR	10 - 1k 1k - 5k	30 + 10 50 + 20	50 + 20 70 + 30	70 + 30 100 + 40	150 200 [8]	250 300 [8]
1.000000mA	1.5kR	10 - 5k 1k - 5k	30 + 10	50 + 20	70 + 30	120	220
10.00000mA	150R	10 - 5k 1k - 5k	30 + 10	50 + 20	70 + 30	120	220
100.0000mA	15R	10 - 5k 1k - 5k	30 + 10	50 + 20	70 + 30	120	220
1.000000A	1.5R	10 - 1k 1k - 5k	30 + 10 50 + 20	50 + 20 70 + 30	70 + 30 100 + 40	150 200 [8]	250 300 [8]

NOTES:

- [1] - For other than Full Range add: ('Wideband' ppm FS) × (Full Range - Output)/(Output).
- [2] - For same conditions between 18°C and 28°C.
- [3] - Includes factory traceability to National Standards and National Standards uncertainty. Datron Instruments traceability approx. SPOT/2.
- [4] - FS = 2 × Full Range.
- [5] - Predominantly second harmonic; negligible error on mean-sensing instruments.
- [7] - Assumes typical thermal transfer measurement.
- [8] - Assumes similar load time constant to that at calibration.

WIDEBAND ACCURACY RELATIVE TO CALIBRATION STANDARDS		SPOT AND WIDEBAND CALIBRATION UNCERTAINTY ±(ppm) [3]	TEMPERATURE COEFFICIENT ±ppm/°C (8°C-18°C and 28°C-40°C)	TOTAL HARMONIC DISTORTION % [5]	TYPICAL OUTPUT IMPEDANCE	OUTPUT COMPLIANCE
±(ppm Output + ppm FS)[4] 23°C ±5°C 90 Days	1 Year					
400 + 50 550 + 80 [8]	500 + 80 650 + 100 [8]	200 500	10 20	0.2 0.5	100MR *	All Ranges: 3V RMS max. 1mH max. $\frac{L}{R}$ or CR time const. < lusec.
220 + 50 350 + 50	350 + 80 450 + 80	100	10	0.2	30MR	
220 + 50 350 + 50	350 + 80 450 + 80	100	10	0.2	3MR	
220 + 50 350 + 50	350 + 80 450 + 80	100	10	0.2	300kR	
400 + 50 550 + 80 [8]	500 + 80 650 + 100 [8]	100 200	20 20	0.2 0.5	30kR **	

*: Typical effective output capacitance = 200pF
 **: Typical effective output capacitance = 0.5µF } Negligible on other Ranges.

OTHER SPECIFICATIONS

Settling Time to 100ppm of Step Size	10 - 32Hz <10s	32 - 330Hz <3s	330Hz - 5kHz <1s
Frequency Accuracy	<100ppm; typically 10ppm.		
Maximum Load Capacitance	10nF		
Maximum Load Inductance	1mH, <1usec.		

DATE	DESCRIPTION	AMOUNT	BALANCE
1950-01-01	Opening Balance	100.00	100.00
1950-01-15	Deposit	50.00	150.00
1950-02-01	Withdrawal	25.00	125.00
1950-02-15	Deposit	75.00	200.00
1950-03-01	Withdrawal	30.00	170.00
1950-03-15	Deposit	60.00	230.00
1950-04-01	Withdrawal	40.00	190.00
1950-04-15	Deposit	80.00	270.00
1950-05-01	Withdrawal	50.00	220.00
1950-05-15	Deposit	90.00	310.00
1950-06-01	Withdrawal	60.00	250.00
1950-06-15	Deposit	100.00	350.00
1950-07-01	Withdrawal	70.00	280.00
1950-07-15	Deposit	110.00	390.00
1950-08-01	Withdrawal	80.00	310.00
1950-08-15	Deposit	120.00	430.00
1950-09-01	Withdrawal	90.00	340.00
1950-09-15	Deposit	130.00	470.00
1950-10-01	Withdrawal	100.00	370.00
1950-10-15	Deposit	140.00	510.00
1950-11-01	Withdrawal	110.00	400.00
1950-11-15	Deposit	150.00	550.00
1950-12-01	Withdrawal	120.00	430.00
1950-12-15	Deposit	160.00	590.00
1951-01-01	Final Balance		590.00

THIS STATEMENT IS SUBJECT TO THE TERMS AND CONDITIONS OF THE ACCOUNT AGREEMENT. THE BALANCE IS SUBJECT TO CHANGE WITHOUT NOTICE. THE ACCOUNT IS NOT TO BE USED FOR ANY OTHER PURPOSES. THE ACCOUNT IS NOT TO BE USED FOR ANY OTHER PURPOSES.

SECTION 7 SPECIFICATION VERIFICATION

Introduction

This section contains the procedures which check the 4200 is working within its specified traceable accuracy. Because most users will wish to verify the 4200 AC voltage via Thermal Transfer standards, the verification procedures assume that this method will be employed. It is also assumed that users will be able to operate their own equipment correctly, according to the manufacturer's instructions. Therefore the procedure concentrates on detailing the operation of the 4200 during verification. Please use the report forms included (on pages 7-6 to 7-9) as masters to generate duplicate copies and record the instruments performance (either on receipt from DATRON or as part of a periodic check). Firstly then, here is an overview of the operations which will be required:

- ① Voltage check using a Thermal Transfer
- ② Linearity check
- ③ Current check using Standard Shunts
- ④ Specifications

① Voltage Check
Select the 4200 OUTPUT RANGE starting with the lowest value in the sequence to reduce the stabilization time for thermal effects at the terminals. Select the desired FREQUENCY RANGE (or Spot F). Press OUTPUT ON and Spec, record the limits under the heading \pm Urppm. (see Report Sheet 7-6 & 7-8)

If the DC standard is adjustable null the Thermal Transfer against the 4200 Full Range value. Configure the Thermal Transfer and DC Standard as required. Adjust the DC Standard to null with the Thermal Transfer. Record the DC Standard error on the Report Sheet.

If the DC standard is non-adjustable null the Thermal Transfer against the DC Standard. Configure the Thermal Transfer as required. Select Error on the 4200 and increment/decrement output to null with the Thermal Transfer, record the MODE display readout on the Report Sheet.

② Linearity Check
May be performed on the 10V range. Check each value in turn in the following order to reduce the stabilization time for thermal effects at the terminals:

1V, 10V, 19V.

The checks may be carried out either at the above values or at user's Reference standard voltages close to the above values. For each check record the results on Report Sheets 7-5 or 7-6 Table 1.b).

③ Current Check
Select the desired frequency (or Spot frequency) set the OUTPUT display to Full Range and determine the error in the shunt voltage developed with a measurement system of suitable accuracy.

④ Specifications
4200 Specifications are available from two sources:
a. Specifications appearing in Section 6
b. Specifications stored within the instrument's non-volatile memory (see Section 4 page 4-12 to 4-13).

In Section 6 all specifications given show Datron's calibration uncertainty in a separate table. The stability and accuracy specifications on their own describe the true performance of the instrument in a form which can be made traceable to National Standards merely by adding in the uncertainty of the reference standard against which it is checked. However, within the instruments' non-volatile memory the figures are compiled as follows:

24hr CALIBRATION INTERVAL
24 Hours Stability figure.

90dy CALIBRATION INTERVAL [see Note]
90 Days Relative Accuracy figure
+ Datron's Calibration Uncertainty.

1yr CALIBRATION INTERVAL [see Note]
1 Year Relative Accuracy figure
+ Datron's Calibration Uncertainty.

The Spec mode facility provides 90 day and 1 year accuracy figures which are traceable through Datron standards to National Standards, for users who have no calibration or verification facilities.

Note. With Spot F selected the Spot F amplitude accuracy + Datron's uncertainty is displayed.

Verification
The 24-hour stability specification can only be verified following calibration against the user's reference standard and a check within 24 hours against the same standard (under the same conditions, including temperature).

The 90-day/1-year tolerances can be calculated ON RECEIPT by adding the users reference standard uncertainty to the Relative accuracy figure + Datron's calibration uncertainty or FOLLOWING USER CALIBRATION by referring to the Relative accuracy figure only (Section 6) + the users uncertainty. Where ambient temperatures are outside the Specified range, temperature coefficient correction should be taken into account.

Report Forms

The report forms provided give columns for the necessary calculations. The report sheets '90dy-Full Range' (7-5 & 7-7) give the absolute limits for Full Range values on each OUTPUT RANGE and FREQUENCY. Only the calibration standard uncertainty absolute value need be added to give the total tolerance limits. This is the usual form for verification on receipt. If a non-adjustable calibration standard is to be used and/or the calibration interval is 24 hours or 1 year use the report sheet 'Limit Calculations' (7-6 & 7-8). No closer verification tolerance than the report sheet calculations give can justifiably be imposed

Example:

If an instrument were correctly calibrated against the factory standard at its uncertainty limit, and then verified against a user's standard, also at its limit; there are two extremes to the range of traceable results which could be obtained. If, for example, both standards' traceable errors were equal and in the same sense, the instrument would appear to verify as absolutely accurate. But if the errors were in opposite sense, it could appear to be inaccurate by the sum of the two limits of uncertainty.

In the following numerical example, a 4200 is

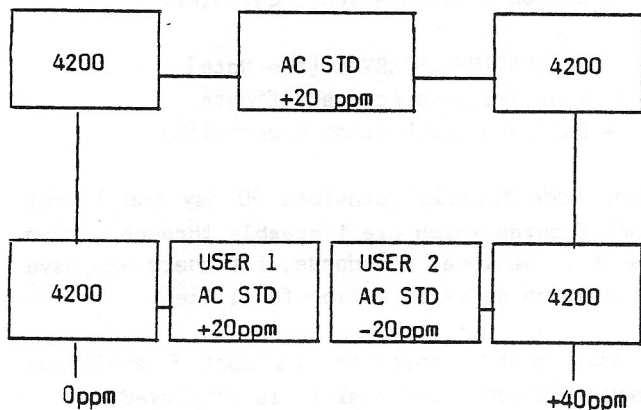

verified in the factory at 10V, 300Hz on the 10V Range, and with 0ppm error against a 20ppm-high standard.

It remains correctly calibrated, and could be delivered to one of two users: one user's standard is 20ppm higher than the National Standard, and the other's is 20ppm lower.

The first user would verify the 4200 as having 0ppm error, but the second would obtain an error of +40ppm; when in fact the instrument had sustained its original accuracy of +20ppm, and all three standards were only 20ppm away from National Standards.

This increased uncertainty is unavoidable unless the same standard is used for each verification. This is clearly not a practical proposition following delivery. But after the first autocalibration against the user's standard, the factory uncertainty is eliminated.

For Verification the following equipment will be required:

Equipment Requirements

① & ② (AC Voltage)

A DC Voltage source calibrated to suitable accuracy.

Example:

Datron 4000 Autocal Standard.

An AC/DC Thermal Transfer

with variable sensitivity, able to withstand 1100V RMS across its input terminals.

③ (AC Current)

The following additional equipment will be necessary:

A set of calibrated AC/DC current shunts of suitable accuracy and equipment capable of measuring the shunt voltage developed.

CAUTION

When choosing a set of current shunts ensure that their power dissipation ratings are sufficient to avoid permanent degradation from the self-heating effects of the current being checked.

The Thermal Transfer

The Thermal Transfer Standard is connected between the DC Voltage Source and the 4200.

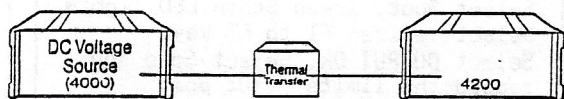

A 4-wire sense connection will reduce inaccuracies due to differences in the output impedances of the DC voltage source and the 4200.

Four points are important:

Start with OUTPUT OFF.

The 4200 should be connected to the Thermal Transfer Standard only when the 4200 OUTPUT OFF LED is lit. (With Output OFF, the I+, I-, Hi and Lo terminals are at high impedance).

Sensitivity.

Always set the Thermal Transfer Standard to its lowest sensitivity before connecting up. Increase sensitivity when necessary to obtain the required input level.

WARNING

During Performance checks and calibration the full range voltage is present at the Thermal Transfer Standard input terminals. On 1000V checks this voltage is potentially lethal, so EXTREME CAUTION must be observed when making adjustments to the Thermal Transfer Standard sensitivity.

CAUTION

The Thermal Transfer Standard used must be able to withstand peak voltages up to 1600V between its input terminals. Such voltages may be present during the time that the 4200 is ramping from zero to 1100V Full Scale after setting OUTPUT ON.

Preparation

Before attempting any verification ensure the following steps are carried out.

- 1 Turn on the instrument to be checked and allow minimum of 2 hours to warm-up in the specified environment.
2. Ensure familiarity with normal operation of the 4200 as described in this Handbook.
3. Cancel any MODE keys, ensure OUTPUT OFF and check that "cal" is not present on the MODE display.
4. Self-Test: select Test to carry-out the test routine described in Section 4. Terminate the test routine.
5. Consult the manufacturer's handbooks before connecting and operating any equipment in the measurement system
6. Interconnections and Guarding: Refer to Section 4 page 4-2.
7. Select 24hr 90dy or 1yr on the CALIBRATION INTERVAL Switch. Refer to section 4 page 13.

Notes

Remote Sense is available as follows:

1V 10V 100V 1000V - Local/Remote Sense
1mV 10mV 100mV - Local Sense only
All current ranges - not applicable
(Local: 2-wire sense Remote: 4-wire sense)
Output must be OFF to change sense connection.

OUTPUT OFF Default. If OUTPUT is ON when changing ranges, it remains on unless the change is to the 1000V RANGE, or ranging up to more than 75V on the 100V RANGE. In these cases the OUTPUT defaults to OFF. (refer to Section 4, pages 4-7 and 4-8).

'ERROR' MODE. Refer to Section 4 pages 14 to 16
FREQUENCY STORE. Refer to Section 4 page 10

SPECIFICATION VERIFICATION

Select 4200 OUTPUT RANGE starting with the lowest value to reduce the stabilization time for thermal effects at the terminals. If required the Error mode can be entered and used to null the 4200 output to the Thermal Transfer and the error then recorded from the MODE/FREQUENCY display. If a non-adjustable DC Standard is used complete the verification through the Non-adjustable selection block.

Wideband Verification

SPOT F Verification

Select FREQUENCY RANGE and increment the FREQUENCY/MODE \uparrow/\downarrow keys to the required value or recall frequency. Store. Select OUTPUT ON. Select Spec and record the limits ($\pm Ur$ ppm)

Select Spot. Green Store LED lights
Select desired F1 to F5 key
Select OUTPUT ON. Select Spec and record the limits ($\pm Ur$ ppm)

Is DC standard adjustable?

YES

NO

Adjustable Standard

Null the Thermal Transfer against the 4200. Configure the DC Standard and Thermal Transfer as required. Adjust the DC Standard to null with the Thermal Transfer. Record the error [see Note 1].

Non-Adjustable Standard

Null the Thermal Transfer against the DC Standard. On the 4200 select Error mode and increment the output with the MODE/FREQUENCY \uparrow/\downarrow keys to obtain a null at the Thermal Transfer Standard. Record the error [see Note 2].

OUTPUT OFF

Is all required voltage verification completed?

YES

NO

Has the instrument verified ?

YES

NO

Leave measurement system in a safe condition or disconnect as required

Reconfigure if required to verify next Range/Frequency configuration

If an instrument is found to be out of specification, refer to the Routine Auto-calibration in Section 8, or contact your nearest Datron Servicing Center.

- Note [1]** Adjustable standard. The error being recorded is the result of subtracting the 4200 output display reading from the DC Standard display.
- [2]** Non-adjustable standard. The error recorded here is the compensation value on the 4200 MODE/FREQUENCY display, however its polarity must be reversed.

CURRENT VERIFICATION

Select 4200 OUTPUT RANGE starting with the lowest value to reduce the stabilization time for thermal effects at the terminals.

Wideband Verification

SPOT F Verification

Select FREQUENCY RANGE and increment the FREQUENCY/MODE \uparrow/\downarrow keys to the required value or recall frequency Store (refer Section 4 page 10). Select OUTPUT ON. Select Spec and record the limits ($\pm U_r$ ppm)

Select Spot. Green Store LED lights Select desired F1 to F5 key Select OUTPUT ON. Select Spec and record the limits ($\pm U_r$ ppm)

Measure the shunt voltage developed Record the error on Table 2.

OUTPUT OFF

Is all required current verification completed?

YES

NO

Has the instrument verified ?

YES

NO

Leave measurement system in a safe condition or disconnect as required

Reconfigure if required to verify next Range/Frequency configuration

If an instrument is found to be out of specification, refer to the Routine Auto-calibration in Section 8, or contact your nearest Datron Servicing Center.

Voltage verification report sheet - 90 day limits - full range outputs

(Use as master for duplicate copies)

Datron Model..... Serial Number..... Calibration Interval..... Stability/Accuracy
 Date..... Checked by..... Company/Dept.....

Note - On receipt of the instrument it is recommended to check at the frequencies shown below.

1. AC VOLTAGE
 a) Full Range Checks.

OUTPUT RANGE/ FREQUENCY	DC Source Null	Tolerance Limits		Cal. Std. Uncert'y.	Total Tolerance Limits		OUTPUT Display Reading for Null
		Upper	Lower		-Lim	+Lim	
1mV 1kHz		1.006,2	.993,8				
1mV 100kHz		1.006,7	.993,3				
10mV 1kHz		10.007,9	9.992,1				
10mV 100kHz		10.012,9	9.987,1				
100mV 1kHz		100.025,0	99.975,0				
100mV 100kHz		100.074,8	99.925,2				
1V 1kHz		1.000,130	.999,870				
1V 500kHz		1.004,608	.995,392				
10V 1kHz		10.001,30	9.998,70				
10V 700kHz		10.046,08	9.953,92				
100V 1kHz		100.013,0	99.987,0				
100V 100kHz		100.027,0	99.973,0				
700V 100kHz		701.046	698.954				
1000V 1kHz		1000.210	999.790				
1000V 30kHz		1000.300	999.700				

b) 10V Range Linearity

OUTPUT RANGE/ FREQUENCY	DC Source Null	Tolerance Limits		Cal. Std. Uncert'y.	Total Tolerance Limits		OUTPUT Display Reading for Null
		Upper	Lower		-Lim	+Lim	
1V 1kHz		1.000,31	0.999,69				
10V 1kHz		10.001,30	9.998,70				
19V 1kHz		19.002,29	18.997,71				

Absolute Error = DC Source Value x Us(ppm) x 10⁶

Positive Limit (+ Lim) = Lower Total Limit - Absolute Error

Negative limit (- Lim) = Upper Total Limit - Absolute Error

Voltage Verification Report Sheet - Limit Calculations

Datron Model..... Serial Number..... Calibration Interval..... Stability/Accuracy
 Date..... Checked by..... Company/Dept.....

Notes: 1 - On receipt of the instrument check at the frequencies shown below.
 2 - Users can choose LF and HF frequencies to suit their applications.

1. AC VOLTAGE
 a) Full Range Checks.

OUTPUT RANGE/ FREQUENCY	DC Source Voltage	Spec Mode Readout (+Ur ppm)	Datron Uncert'y. (+Ud ppm)	Cal. Std. Uncert'y. (+Us ppm)	Calculated Tolerance Limits		OUTPUT Display Reading for Null
					-Lim	+Lim	
1mV 1kHz							
1mV 100kHz							
10mV 1kHz							
10mV 100kHz							
100mV 1kHz							
100mV 100kHz							
1V 1kHz							
1V 500kHz							
10V 1kHz							
10V 700kHz							
100V 1kHz							
100V 100kHz							
700V 100kHz							
1000V 1kHz							
1000V 30kHz							

b) 10V Range Linearity

Nominal Value	DC Source Voltage	Spec Mode Readout (+Ur ppm)	Datron Uncert'y. (+Ud ppm)	Cal. Std. Uncert'y. (+Us ppm)	Calculated Tolerance Limits		OUTPUT Display Reading for Null
					-Lim	+Lim	
1V 1kHz							
10V 1kHz							
19V 1kHz							

i. On Receipt from Datron.

Set the CALIBRATION INTERVAL switch to 90dy or 1yr with OUTPUT OFF, set the 4200 OUTPUT display to the value (V) at which the 4200 is to be verified, at the required frequency. Obtain the calibration uncertainty of the standard to be used to verify the 4200, at this output. Add the standard's uncertainty (Us ppm) to the 4200 'Spec' mode 90-day readout (Ur ppm) at this value.

Let the total be Ut (ppm):
 $Ut = Ur + Us$ (ppm).

Calculate the limits from : (i & ii)

$$\text{Positive Limit (+Lim)} = V + \frac{(V \times Ut)}{10^6}$$

$$\text{Negative Limit (-Lim)} = V - \frac{(V \times Ut)}{10^6}$$

ii. Following User-calibration.

Select the appropriate CALIBRATION INTERVAL and with OUTPUT OFF, set the 4200 OUTPUT display to the value (V) at which the 4200 is to be verified, at the required frequency. Obtain the calibration uncertainty of the standard to be used to verify the 4200, at this output. Add the standard's uncertainty (Us ppm) to the 4200 'Spec' mode display readout (Ur ppm), then if on 90dy 1yr calibration interval subtract Datron's calibration uncertainty (Ud ppm) at this value.

Total Uncertainty Ut (ppm) for:

$$90dy/1yr = Ur + Us - Ud \text{ (ppm)}$$

$$24hr = Ur + Us \text{ (ppm)}$$

Current Verification upon receipt - 90 day limits - full range outputs

(Use as master for duplicate copies)

2. CURRENT

Full Range Checks

OUTPUT RANGE/ FREQUENCY	Shunt Value	DC Source Voltage	Tolerance Limits		Cal. Std. Uncert'y. ($\pm U_s$ ppm)	Total Tolerance Limits		OUTPUT Display Reading for Null
			Upper	Lower		-Lim	+Lim	
100 μ A 300Hz			100.070,0	99.930,0				
100 μ A 5kHz			100.120,8	99.879,2				
1mA 300Hz			1.000,420	999,580				
1mA 5kHz			1.000,550	.999,450				
10mA 300Hz			10.004,20	9.995,80				
10mA 5kHz			10.005,50	9.994,50				
100mA 300Hz			100.042,0	99.958,0				
100mA 5kHz			100.055,0	99.945,0				
1A 300Hz			1.000,600	.999,400				
1A 5kHz			1.000,908	.999,092				

Absolute Error = DC Source Value $\times U_s(\text{ppm}) \times 10^6$

Positive (+ Lim) = Lower Total Limit - Absolute Error

Negative (- Lim) = Upper Total Limit - Absolute Error

Current Verification Report Sheet - Limit Calculations

2. Full Range Checks

OUTPUT RANGE/ FREQUENCY	Shunt Value	DC Source Voltage	Spec Mode Readout ($\pm U_r$ ppm)	Datron Uncert'y. ($\pm U_d$ ppm)	Cal. Std. Uncert'y. ($\pm U_s$ ppm)	Calculated Tolerance Limits		OUTPUT Display Reading for Null
						-Lim	+Lim	
100 μ A 300Hz								
100 μ A 5kHz								
1mA 300Hz								
1mA 5kHz								
10mA 300Hz								
10mA 5kHz								
100mA 300Hz								
100mA 5kHz								
1A 300Hz								
1A 5kHz								

i. On Receipt from Datron.

Set the CALIBRATION INTERVAL switch to 90dy or 1yr with OUTPUT OFF, set the 4200 OUTPUT display to the value (V) at which the 4200 is to be verified, at the required frequency. Obtain the calibration uncertainty of the standard to be used to verify the 4200, at this output. Add the standard's uncertainty (U_s ppm) to the 4200 'Spec' mode 90-day readout (U_r ppm) at this value.

Let the total be U_t (ppm):
 $U_t = U_r + U_s$ (ppm).

Calculate the limits from : (i & ii)

$$\text{Positive Limit (+Lim)} = V + \frac{(V \times U_t)}{10^6}$$

$$\text{Negative Limit (-Lim)} = V - \frac{(V \times U_t)}{10^6}$$

ii. Following User-calibration.

Select the appropriate CALIBRATION INTERVAL and with OUTPUT OFF, set the 4200 OUTPUT display to the value (V) at which the 4200 is to be verified, at the required frequency. Obtain the calibration uncertainty of the standard to be used to verify the 4200, at this output. Add the standard's uncertainty (U_s ppm) to the 4200 'Spec' mode display readout (U_r ppm), then if on 90dy 1yr calibration interval subtract Datron's calibration uncertainty (U_d ppm) at this value.

Total Uncertainty U_t (ppm) for:

$$90dy/1yr = U_r + U_s - U_d \text{ (ppm)}$$

$$24hr = U_r + U_s \text{ (ppm)}.$$

SECTION 8 ROUTINE AUTOCALIBRATION

Users requiring to verify the specification without adjustment to the instrument's calibration status refer to Section 7. For full information on calibration of the 4200 refer to the Calibration and Servicing Handbook, Section 1.

The 4200 Autocal Feature.

Using the standard "Autocal" feature, the 4200 is calibrated entirely from the front panel. Because it is not necessary to remove the covers, thermal disturbance is avoided and the 4200 can be put back into service immediately after calibration.

Users wishing to maintain the highest specification (24 Hours) can recalibrate daily, on a regular basis, if desired. The procedures contained in this Section provide the essential information for setting up such routines. It is not necessary to update all ranges, as it is possible to 'wideband' calibrate one output range or SPOT calibrate at a single frequency.

During the Autocal process, the microprocessor adjusts correction factors which are already stored in non-volatile memories. After adjustment, the updated factors are continuously applied to correct the 4200 output amplitude.

Special keys are used in the Autocal mode. They are illustrated below:

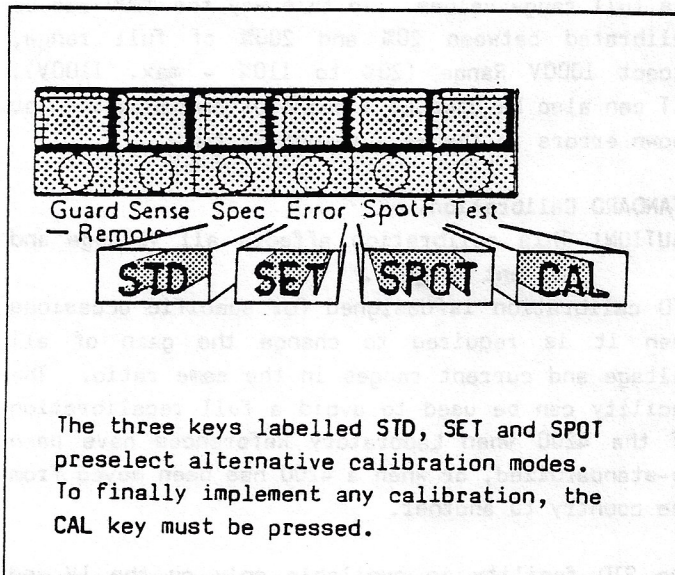

These keys are activated by a simple procedure. On the rear panel there are two switches: the IEEE 488 address switch, and a security keyswitch labelled RUN/CAL ENABLE. By setting the address switch to 31 (ADD 11111), and the keyswitch to CAL ENABLE, four of the front panel MODE keys are reassigned to calibration functions, permitting access to the correction memories.

The activation procedure is illustrated below:

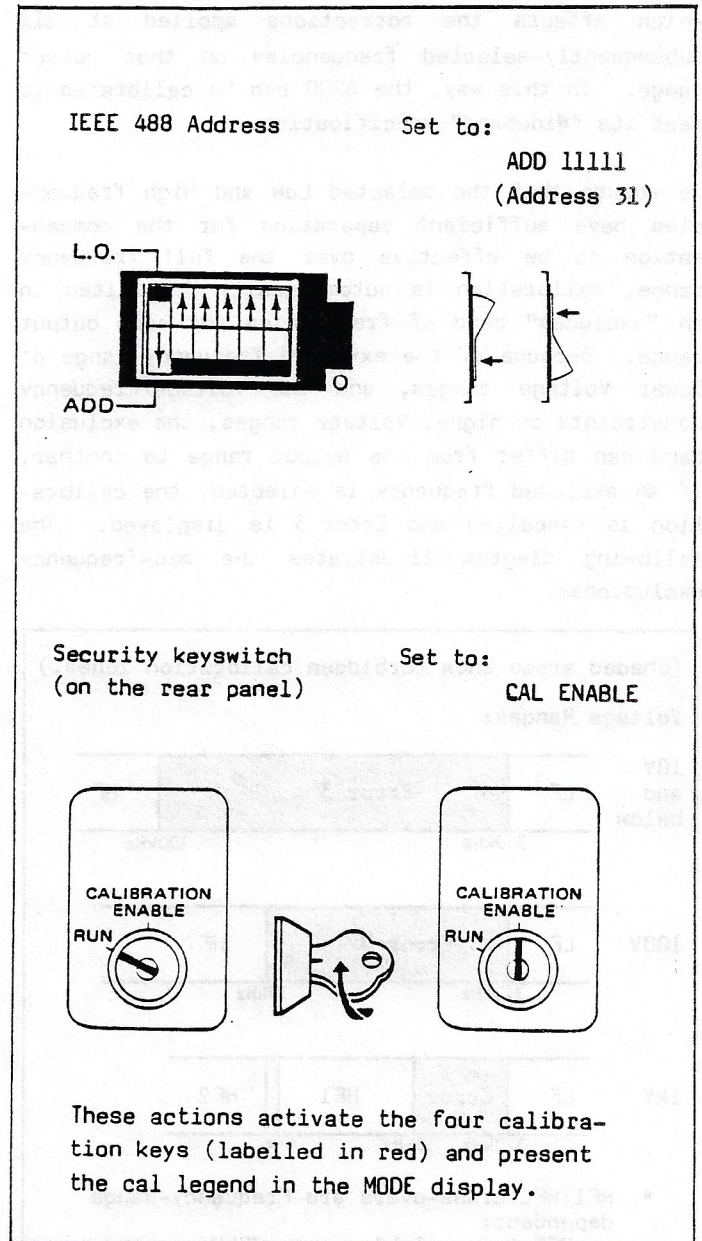

Once the keys are activated, four modes of calibrating the 4200 become available. They are given the following names:

- "WIDEBAND", using only the CAL key;
- "SET", using SET and CAL keys in sequence;
- "SPOT", with or without SET, triggered by CAL;
- "STANDARD" using STD and CAL keys in sequence.

The meanings of the names, and the detailed procedures for using the modes, are described overleaf.

"Wideband" Calibration.

When CAL is pressed without preselecting SET, SPOT or STD; the 4200 makes two assumptions:

1. that each OUTPUT Range is to be calibrated at the exact Full Range value, and
2. that two calibrations will be performed, one at low frequency, the other at high frequency.

This allows two correction values to be stored for each output range. From their difference, the microprocessor calculates a compensation factor, which affects the corrections applied at all subsequently-selected frequencies on that output range. In this way, the 4200 can be calibrated to meet its "Wideband" specification.

To ensure that the selected Low and High frequencies have sufficient separation for the compensation to be effective over the full frequency range, calibration is automatically prohibited in an "excluded" band of frequencies for each output range. Because of the extended frequency range of lower Voltage ranges, and the Voltage/Frequency constraints on higher Voltage ranges, the exclusion band can differ from one output range to another. If an excluded frequency is selected, the calibration is cancelled and Error 3 is displayed. The following diagram illustrates the mid-frequency exclusions:

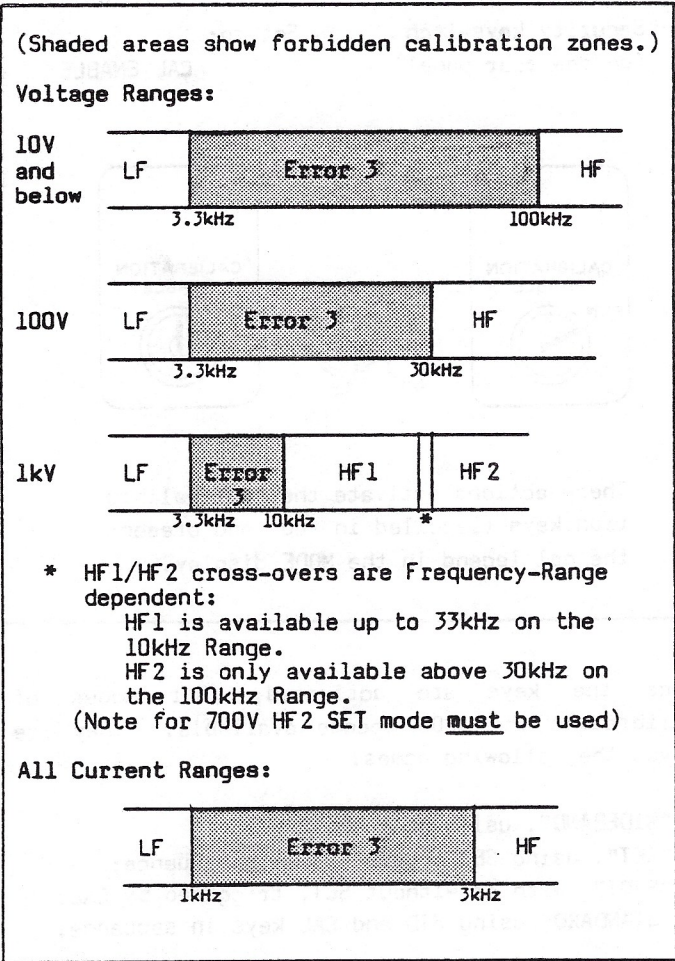

SPOT Calibration.

For each Output Range, a user may select five frequencies for SPOT calibration. The microprocessor stores the spot frequencies, and their amplitude corrections, in memories which are completely separate from those used for wideband corrections. Enhanced accuracy is obtained at these spots, as any flatness errors in the wideband correction are eliminated.

Procedural Notes:

When SPOT is pressed the 4200 assumes that the spot frequency is to be changed, and so defaults frequency to 1kHz.

Spot calibration achieves highest specification if calibrated at the Full Range value. Spot frequency accuracy tables are given in Section 6. For Recall procedures see Section 4, page 4-11.

When the 4200 is shipped the Spot frequencies are not calibrated unless specified in the customer's order.

When used with SET, SPOT calibration can be carried out within 10% of full range value.

SET Calibration.

If WIDEBAND or SPOT Calibration is to be carried out with sources which are not exactly at Full Range, then the SET preselection key allows the 4200 to be prepared for calibration at other than its full range values. In this way the 4200 can be calibrated between 20% and 200% of full range, except 1000V Range (20% to 110% - max. 1100V). SET can also be used as a means of compensating for known errors in the Measurement System.

STANDARD Calibration.

CAUTION! This calibration affects all Voltage and Current Ranges!.

STD calibration is designed for specific occasions when it is required to change the gain of all voltage and current ranges in the same ratio. The facility can be used to avoid a full recalibration of the 4200 when Laboratory References have been re-standardized, or when a 4200 has been moved from one country to another.

The STD facility is available only on the 1V and 10V Ranges, and is restricted to 100Hz and 1kHz Frequency Ranges. Its procedure differs from SET calibration only in the use of the STD key instead of the SET key. When the CAL key is finally pressed to trigger the calibration, all of the voltage and current range gains are adjusted in the same ratio.

The STD, SET and SPOT keys have toggle action.

Calibration Procedures.

Introduction.

Because most users will calibrate the 4200 via thermal transfer standards, the calibration procedures assume that this method will be employed. However, details of setting up a thermal transfer standard are not included, as several different models are in use, each with their own methods of connection and procedures.

Instead it is assumed that users will be able to operate their own equipment correctly, according to the manufacturer's instructions. The procedures which follow therefore concentrate on detailing the operation of the 4200 during calibration, accepting that the required thermal transfer will be set up to a DC source of suitable accuracy.

Firstly, here is an overview of the operations which will be required.

GENERAL PROCEDURE.

Voltage Calibration using a Thermal Transfer.

Select the desired frequency (or Spot frequency), set the OUTPUT display to the Calibration Standard value, and switch the 4200 output ON. If calibrating at a non-nominal voltage value, SET will need to be selected. Adjust the 4200 output to obtain a null at the Calibration Standard value, and press the CAL key to execute the calibration.

Current Calibration using Standard Shunts.

Select the desired frequency (or SPOT frequency), set the OUTPUT display to Full Range and increment or decrement to give the required value in the measurement system. If calibrating at a non-nominal current value SET must be selected. The CAL key is pressed to execute the calibration.

To "Standardize!" all Ranges.

The Voltage procedure is used, but pressing STD instead of SET on the 1V/10V Range. Do not "Standardize" unless it is necessary for the reasons quoted on page 8-2.

WARNING

During Performance checks and calibration the full range voltage is present at the Thermal Transfer Standard input terminals. On 1000V checks this voltage is potentially lethal, so EXTREME CAUTION must be observed when making adjustments to the Thermal Transfer Standard sensitivity.

General Notes.

Remote Sense is available as follows:

1V 10V 100V 1000V - Local/Remote Sense

1mV 10mV 100mV - Local Sense only

All current ranges - not applicable

(Local: 2-wire sense Remote: 4-wire sense)

Output must be OFF to change sense connection.

OUTPUT OFF Default.

If OUTPUT is ON when changing ranges, it remains on unless the change is to the 1000V RANGE, or ranging up to more than 75V on the 100V RANGE. In these cases the OUTPUT defaults to OFF.

(refer to Section 4, pages 4-7 and 4-8).

High Frequency Calibrations.

Several passes may be required to achieve satisfactory calibration, particularly if the initial errors are large or the calibration takes longer than required by the Transfer System in use. Repeat procedure as required.

1000V Range: LF calibration must be completed first. However HF1/HF2 bands may, if the user requires, be calibrated in reverse order. SET mode must be used for 700V/HF2.

SPOT Memory Erasure.

To prevent unwanted calibrations at obsolete spot frequencies, it is possible to "Uncalibrate" any spot frequency on any range. The procedure is:

Select Zero Output, set Output On and Press CAL.

When the CAL ENABLE/RUN Switch is set to RUN, any selection of that particular Spot F will cause the uncalibrated message "SFX ----" to be shown on the MODE/FREQUENCY display.

Preparation

Before any calibration is carried out, prepare the 4200 as follows:

1. Turn on the instrument to be checked and allow minimum of 4 hours to warm-up in the specified environment.
2. Ensure familiarity with normal operation of the 4200 described in this Handbook.
3. Consult the manufacturer's handbooks before connecting and operating the Thermal Transfer Standard and the DC Voltage source.
4. Refer to 'Use of the Thermal Transfer Standard' in Section 7.
5. Interconnections and Guarding: Refer to Section 4, page 4-2.
6. Cancel any **MODE** keys, ensure **OUTPUT** set to **OFF**.
7. IEEE 488 Address switch: Set to **ADD 11111** (Address 31) as shown earlier.
8. **CALIBRATION ENABLE** key switch: Insert Calibration Key and turn to **ENABLE**.
9. Set the Calibration Interval Switch to 24 hr.

WARNING

During the Performance checks and calibration, the full range voltage is present at the Thermal Transfer Standard input terminals. On 1000V checks this voltage is potentially lethal, so **EXTREME CAUTION** must be observed when making adjustments to the Thermal Transfer Standard sensitivity.

VOLTAGE CALIBRATION PROCEDURE

[1] Note: If the AC Transfer null is nominal Full Range value of the 4200, use wideband or spot cal without SET. If the AC Transfer null is known NOT to be a nominal 4200 Full Range value, SET must be selected and:

- a. The non-nominal DC Standard value entered and/or.....
- b. The Measurement system error corrections applied via SET selection Configure the DC Standard and Thermal Transfer as required and obtain a null against the DC Standard.

WIDEBAND CAL

This procedure is used for two calibrations on each range (1V to 100V) three calibrations on 1000V range. First LF then HF with or without SET adjustment

SPOT CAL

This calibration is unaffected by existing or subsequent wideband calibration. This procedure can be used with or without SET adjustment

STD

Adjusts all of the Wideband and Spot calibrations. Perform once on the 1V or 10V range. STD adjustment gives possible non-nominal Standard value

Select **FREQUENCY RANGE** and increment the **FREQUENCY/MODE** \uparrow/\downarrow keys to the required value
Select **OUTPUT RANGE** and **OUTPUT ON**

Select **SPOT Green Store LED** lights
Select desired **F1-F5** key and increment **FREQUENCY** \uparrow/\downarrow to the required value
Select **OUTPUT RANGE** and **OUTPUT ON**

Select **FREQUENCY RANGE** and increment the **FREQUENCY/MODE** \uparrow/\downarrow keys to the required value
Select **OUTPUT RANGE** and **OUTPUT ON**

Is the Measurement system set to give an AC Null at the 4200 nominal Full Range value? See [1]

YES

NO

Enter correction (SET)

Adjust **OUTPUT** \uparrow/\downarrow keys to display the value of the DC Standard (\pm Measurement System errors if appropriate) See [1]
Press **SET** to inform the 4200 that the calibration is to be carried out at this value. The instrument duplicates the output value on the **MODE/FREQUENCY** display replacing the frequency value.

Standardization(STD)

Adjust **OUTPUT** \uparrow/\downarrow keys to display the value of the DC Standard (\pm Measurement System errors if appropriate) See [1]
Press **STD** to inform the 4200 that calibration is to be carried out at this value. The instrument duplicates the output value on the **MODE/FREQUENCY** display replacing the frequency value.

Output adjustment

Use **OUTPUT/!** keys to null the output against the Thermal Transfer. (the **OUTPUT** display changes during this adjustment). To execute calibration press **CAL**

OUTPUT OFF

Is all required voltage calibration completed?

YES

NO

Restore IEEE address if 4200 is used on a system.
Turn calibration key to **RUN** and remove the calibration key

Reconfigure if required to calibrate next Range/Frequency

CURRENT CALIBRATION

Select 4200 current range starting with the lowest value to reduce the stabilization time for thermal effects at the terminals. Ensure the measurement system is standardized to the required flatness and accuracy.

Wideband Verification

SPOT F Verification

Select FREQUENCY RANGE and increment the FREQUENCY/MODE \uparrow/\downarrow keys to the required value. Select OUTPUT ON. Select Spec and record the limits

Press and release the SPOT F key. Its LED and green Store LED lights. Select OUTPUT ON. Select Spec and record the limits.

Will the required shunt voltage developed be obtained at a nominal 4200 Full Range current value?

YES

NO

Adjust OUTPUT \uparrow/\downarrow keys to display the value of the current required. Press SET to inform the 4200 that the calibration is to be carried out at this value. The instrument duplicates the output value on the MODE/FREQUENCY display replacing the frequency value.

Measure the voltage developed across the Shunt resistor. Use OUTPUT \uparrow/\downarrow keys to obtain reading in measurement circuit of the required value. (the OUTPUT display changes during this adjustment). To execute the calibration press CAL.

Is all calibration required complete?

YES

NO

Leave measurement system in a safe condition or disconnect as required

Restore IEEE address if 4200 is used on a system.
Turn calibration key to RUN and remove the key.

Reconfigure if required to verify next Range/Frequency configuration



SALES AND SERVICE REPRESENTATIVES WORLDWIDE

UNITED KINGDOM

Datron Instruments Ltd
Hurricane Way
Norwich Airport Industrial Estate
Norwich
Tel: (0603)404824
Tlx: 975173

UNITED STATES & CANADA

Datron Instruments Incorporated
3401 SW 42nd Street
Stuart
Florida 33497
Tel: 305-283-0935
Tlx: 230525724

AUSTRALIA

The Dindima Group Pty Ltd
P O Box 106
Vermont
Victoria 3133
Tel: (3)8734455
Tlx: AA36819

EGYPT & MIDDLE EAST

EPIC
20 Ashmoun St.
P O Box 2682
Horria
Heliopolis
Tel: 661767
Tlx: 23315 EPIC UN

INDIA

Electronic Enterprises
PB No. 6367
Unit 216
Regal Industrial Estate
Acharya Donde Marg
Sewri, Bombay 400 015
Tel: (22)8827096
Tlx: 1171071

NORWAY

Norsk Marconi
Ryensvingen 5
P O Box 50
Manglerud
Oslo 6
Tel: (2)670480
Tlx: 17140

AUSTRIA

Kontron GmbH & Co
Electronics Department
Eisgrubengasse 6
A-2334 Voesendorf
Tel: (222)670031
Tlx: 131699

EIRE

Calibration Specialists Limited
10 Enterprise Centre
Childers Road
Ballysimon
Limerick
Tel: 061-41304

INDONESIA

P.T. & P.D. Bah Bolon Trading Co
Jalan Tana Abang iv No 17
Jakarta Pusat
Tel: 343317/354973
Tlx: 46164

NEW ZEALAND

S D Mandeno Electronic Equip Co
10 Woodhall Road
Epsom
AUCKLAND 3
Tel: (9)600008
Tlx: 21997

BELGIUM

MCR Electronic Marketing
100 Chaussee de Nivelles
1420 Braine L'Alleud
Tel: (2)3848062
Tlx: 62569

FINLAND

Finn Metric OY
PB4, Riihitontuntie
SF 02201, ESPOO 20
Tel: (0)423911
Tlx: 122018

ISRAEL

Madel Technology Ltd
17a Romanili Str
Shikun Dan
Tel-Aviv
Tel: (3)494179
Tlx: 361579

PAKISTAN

CMC
22 Fareed Chambers
Abdullah Haroon Road
Karachi-3
Tel: 516134
Tlx: 25433

BRAZIL

Commercial Goncalves
Loja 01029
Rua Florencio de Abreu 559
San Paulo SP
Tel: 2277082
Tlx: 22104

FRANCE

JOD Electronique
9 Rue Noblet
92500 Rueil Malmaison
Tel: (1)7497044
Tlx: 201626

ITALY

Telav International SRL
Viale Leonardo da Vinci 43
20090 Trezzano sul Naviglio
Milano
Tel: (2)4455741
Tlx: 312827

SINGAPORE & MALAYSIA

Singapore Electronic and
Engineering (Private) Ltd
General Engineering Division
Naval Base Sembawang
P O Box 16 Singapore 9175
Tel: 2570211
Tlx: 21901

CHINA

The First Radio Factory
of Tianjin
No.5 Zhao Jia Chang Street
Hong Qiao Section
Tianjin
Tel: 50710
Tlx: 23265

GERMANY

Wavetek Electronics GmbH
Hans-Pinsel Strasse 9-10
8013 Haar b. Munchen
MUNCHEN
West Germany
Tel: (89)465062
Tlx: 5212996

JAPAN

Cornes & Co
8th Floor Maruzen Building
3-10 Nihonbashi 2 Chome
Chuo-Ku, Tokyo
Tel: (3)2725771
Tlx: 2222987

SOUTH AFRICA

Measuretest (Pty) Ltd
P O Box 61677
Marshalltown 2107
Transvaal
Tel: (11)834-5861
Tlx: 8-6212 SA

DENMARK

CKI
187 Islevdalvej
2880 Kobenhavn-Bagsvaerd
DK 2610 Rydovre
Tel: (452)944411
Tlx: 35363

GREECE

American Technical Enterprise
P O Box 156
48 Patission Street
Athens 147
Tel: (1)8219470
Tlx: 216046

KOREA

Myoung Corporation
CPO Box 8892
Seoul
Tel: (8)439942/437117
Tlx: K24283 Myoung

SWEDEN

Ferner Electronics AB
Box 125
16126 BROMMA
Tel: (08)802540
Tlx: 10312

EASTERN EUROPE

Data Loop Ltd
'The Coach House'
Tower Hill, Dorking
Surrey RH4 2AN
England
Tel: (0306)881166
Tlx: 859417

HONG KONG

Eurotherm (Far East) Ltd
49-51 Wong Chuk Hang Road
Flat A and B
19/F Derrick Industrial Building
Aberdeen, Hong Kong
Tel: (5)546391
Tlx: 72449

NETHERLANDS

Air Parts International BV
P O Box 255
12 Kalkovenweg
2400 AG Alphen a.d. Rijn
Tel: (01720)29300
Tlx: 39564

SWITZERLAND

Precitek Electronic AG
Bahnhofstrasse 358B
CH-8107
Buchs/Zurich
Tel: (1)8442950
Tlx: 56377

For Customers in countries not listed above please contact DATRON INSTRUMENTS LIMITED in the United Kingdom.